



09.07.2022, 17:20 Uhr

[🏠](#) > Erdbeben erschüttert Schwäbische Alb - Stärke 4,1 gemessen

## Erdbeben erschüttert Schwäbische Alb - Stärke 4,1 gemessen

Die Schwäbische Alb ist am Samstag von einem kräftigen Erdbeben erschüttert worden. Das Beben hatte eine Stärke von 4,1, sein Epizentrum lag nahe der Stadt Hechingen im Zollernalbkreis. Laut Berichten war das Beben auch in Bayern zu spüren.

Von  BR24 Redaktion

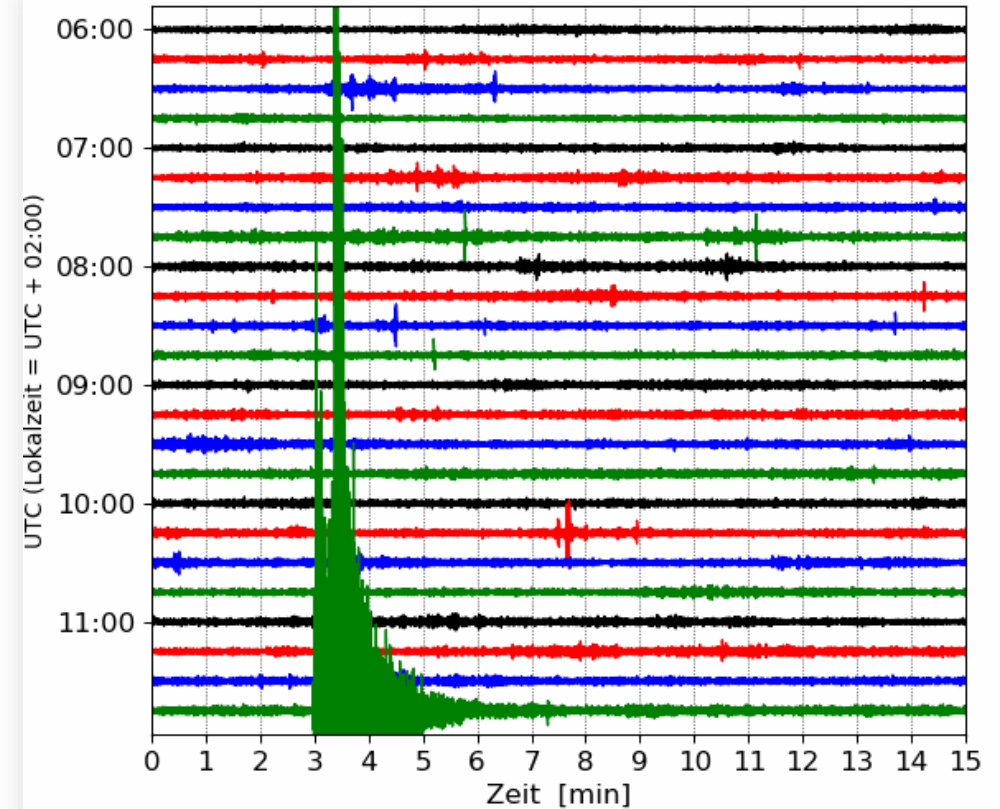

# Erdbeben und Seismotektonik

Welche Spuren hinterlassen Erdbeben im Gelände?

Gibt es einfache Modelle dafür (-> elastic rebound)?

Was ist das einfachste physikalische Modell für ein Erdbeben?

Wie kann ich Erdbeben*herd*parameter bestimmen?

Was bestimmt die Energie (Magnitude, Stärke) von Erdbeben?

Sind kleine und große Erdbeben anders?

Was kann man über die Statistik von Erdbeben sagen?

## *Fault Scarps*

Verwerfungen an der  
Oberfläche

# Fault scarps



California

# Fault scarps



Grand Canyon

# Fault scarps

California



# Fault scarps



California

# Fault scarps



Taiwan



# Fault scarps



Taiwan

# Epicentre Landers, CA

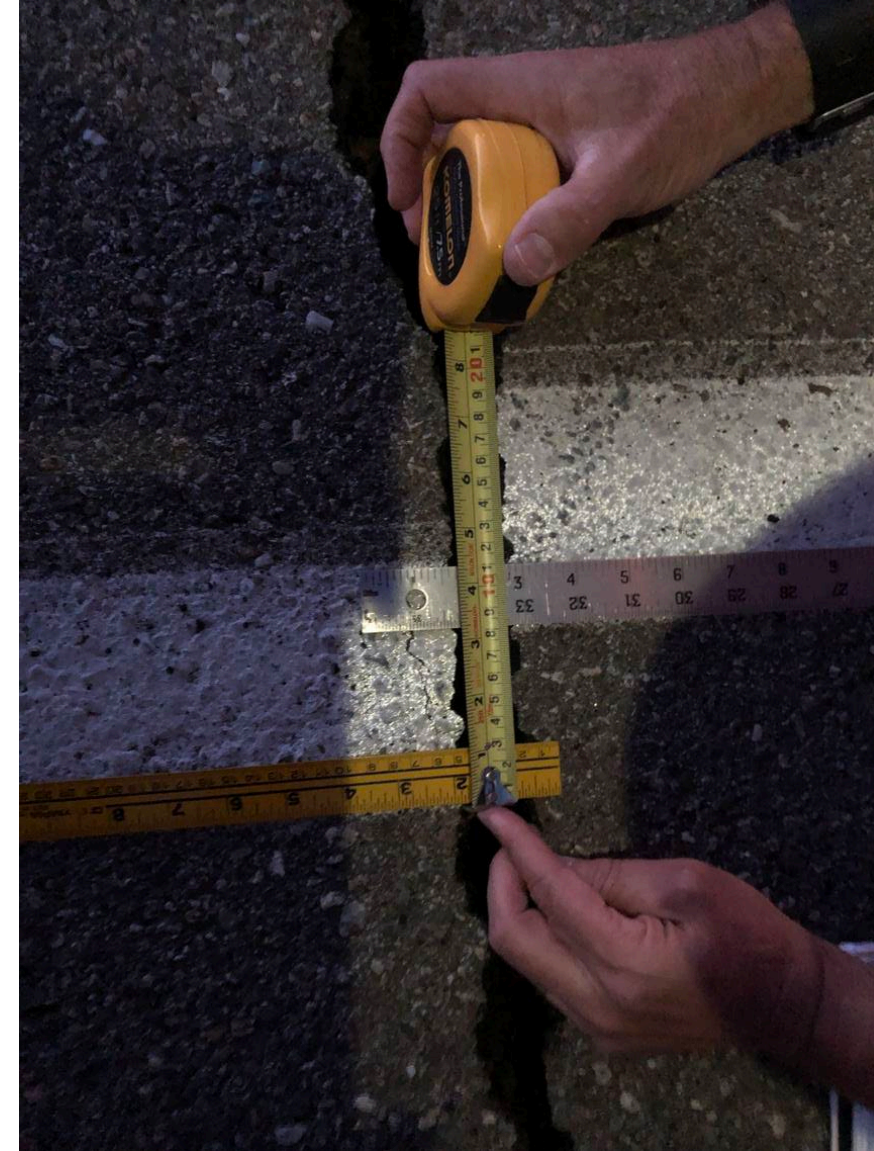

Gibt es einfache Modelle dafür (-> elastic rebound)?

*... Great timing for engineers after the 1906 earthquake in San Francisco ...*

# Elastic rebound

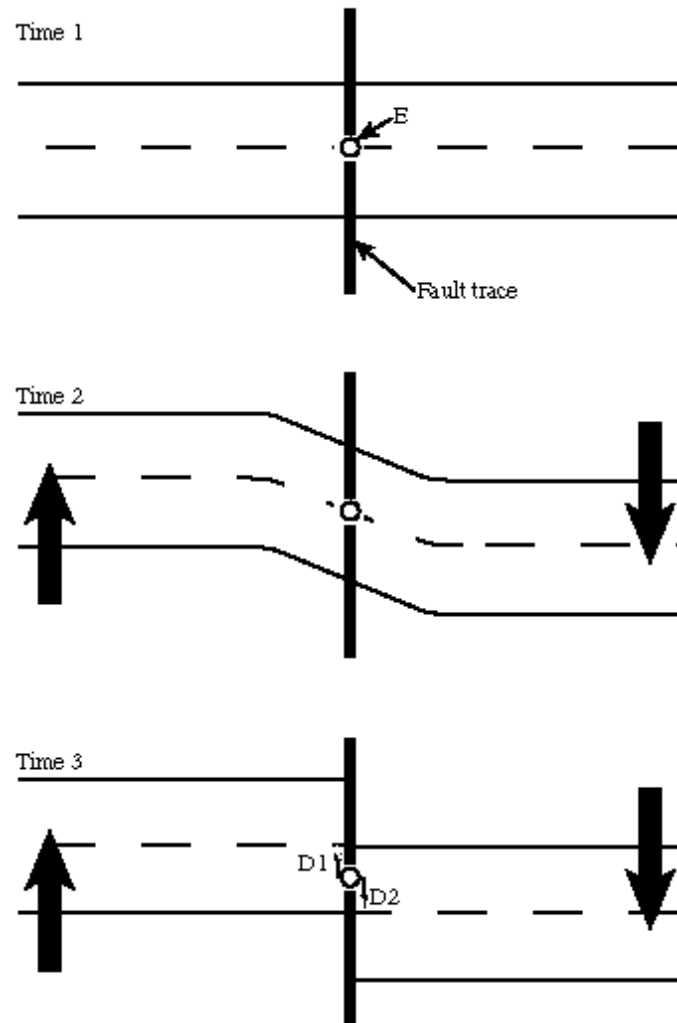

## Recurrence model

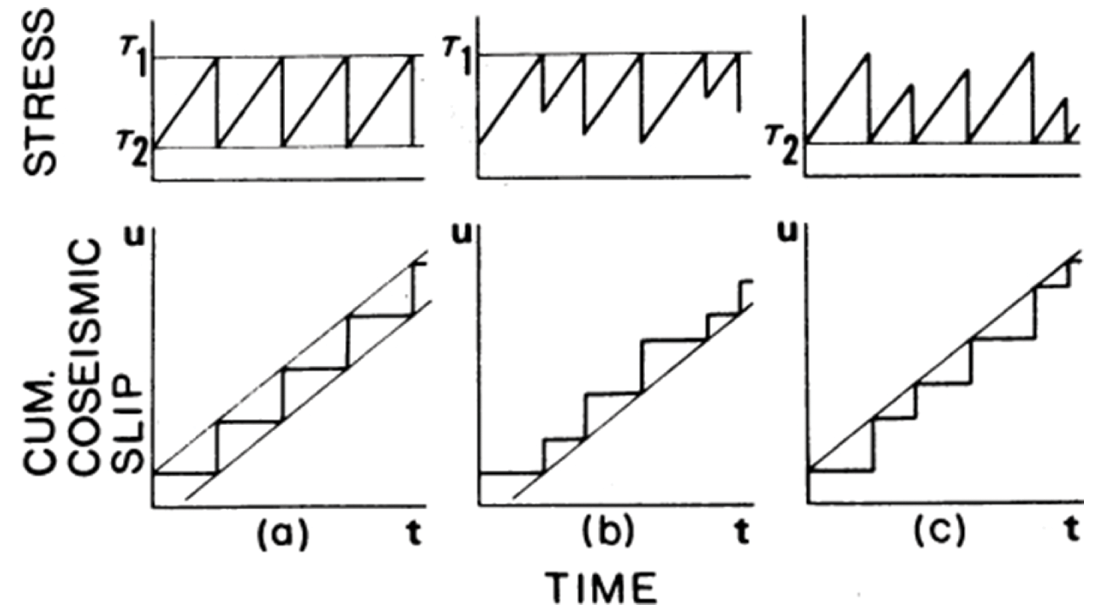

# Deformation - Strain

**Figure 4.5-13: Fault-parallel horizontal interseismic motion across the San Andreas fault.**

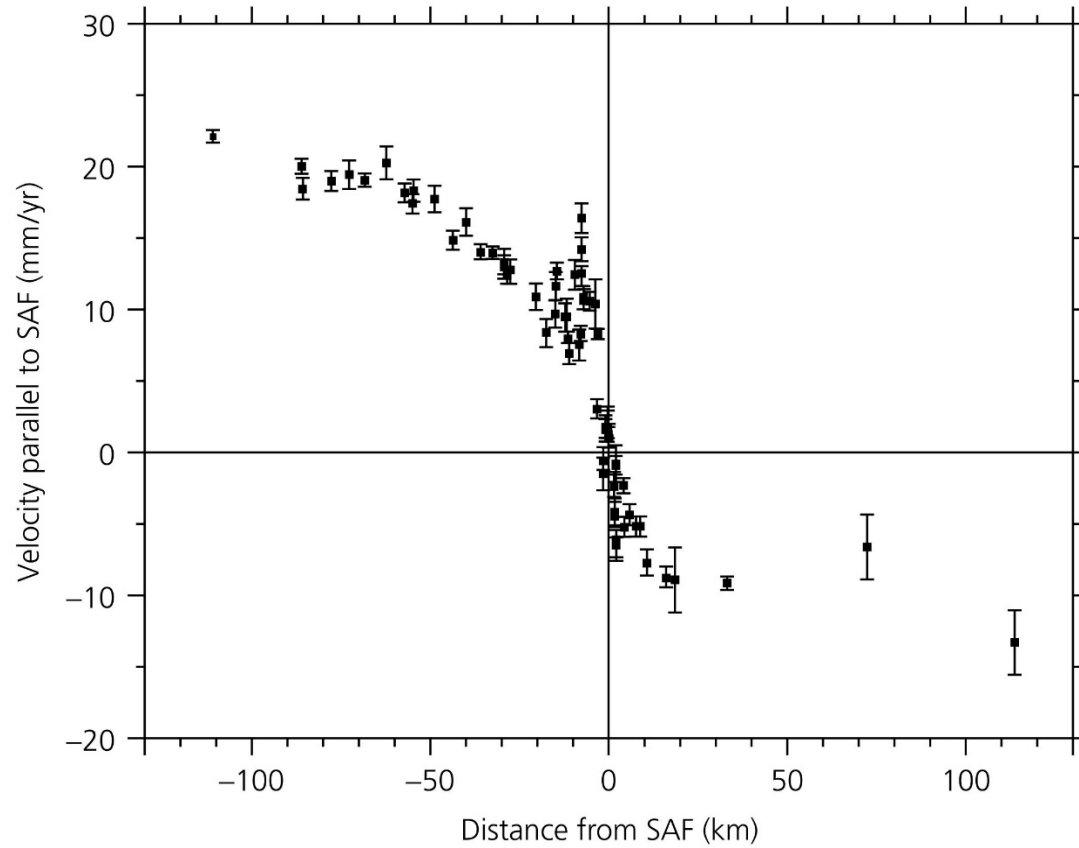

Berkeley Football Stadium

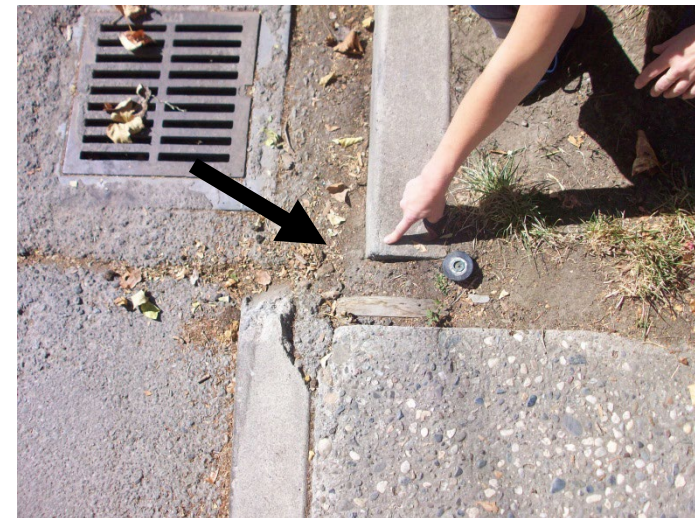
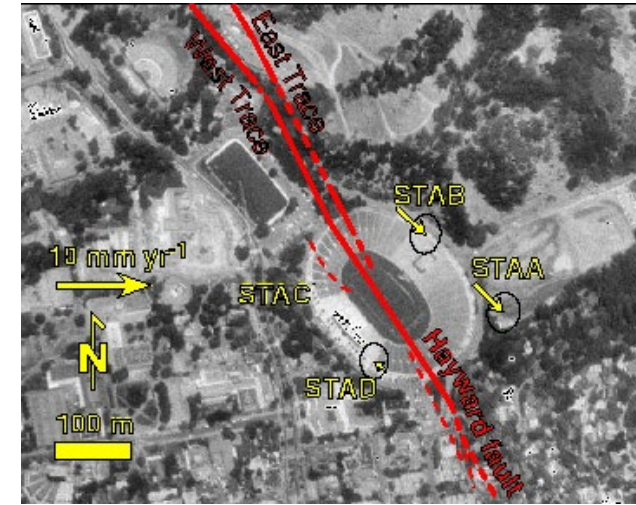

# **Erdbeben Modell**

Punktquelle

Scherdislokation

# Single and double couples

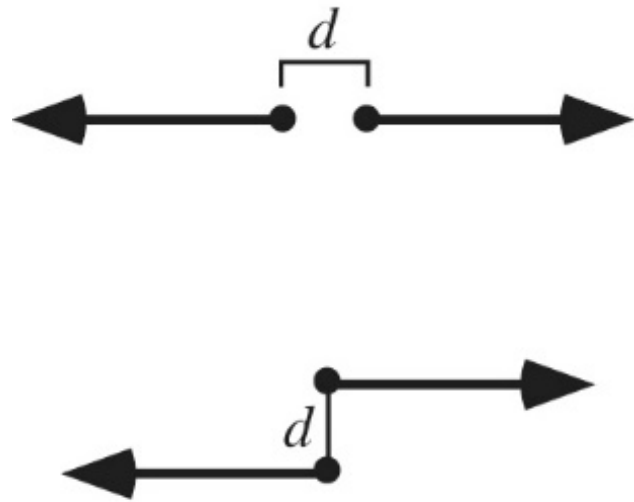

Force Couples

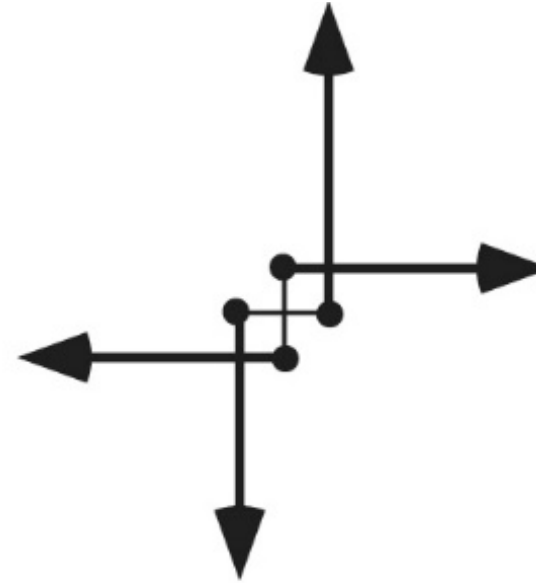

Double Couple

# Seismic sources

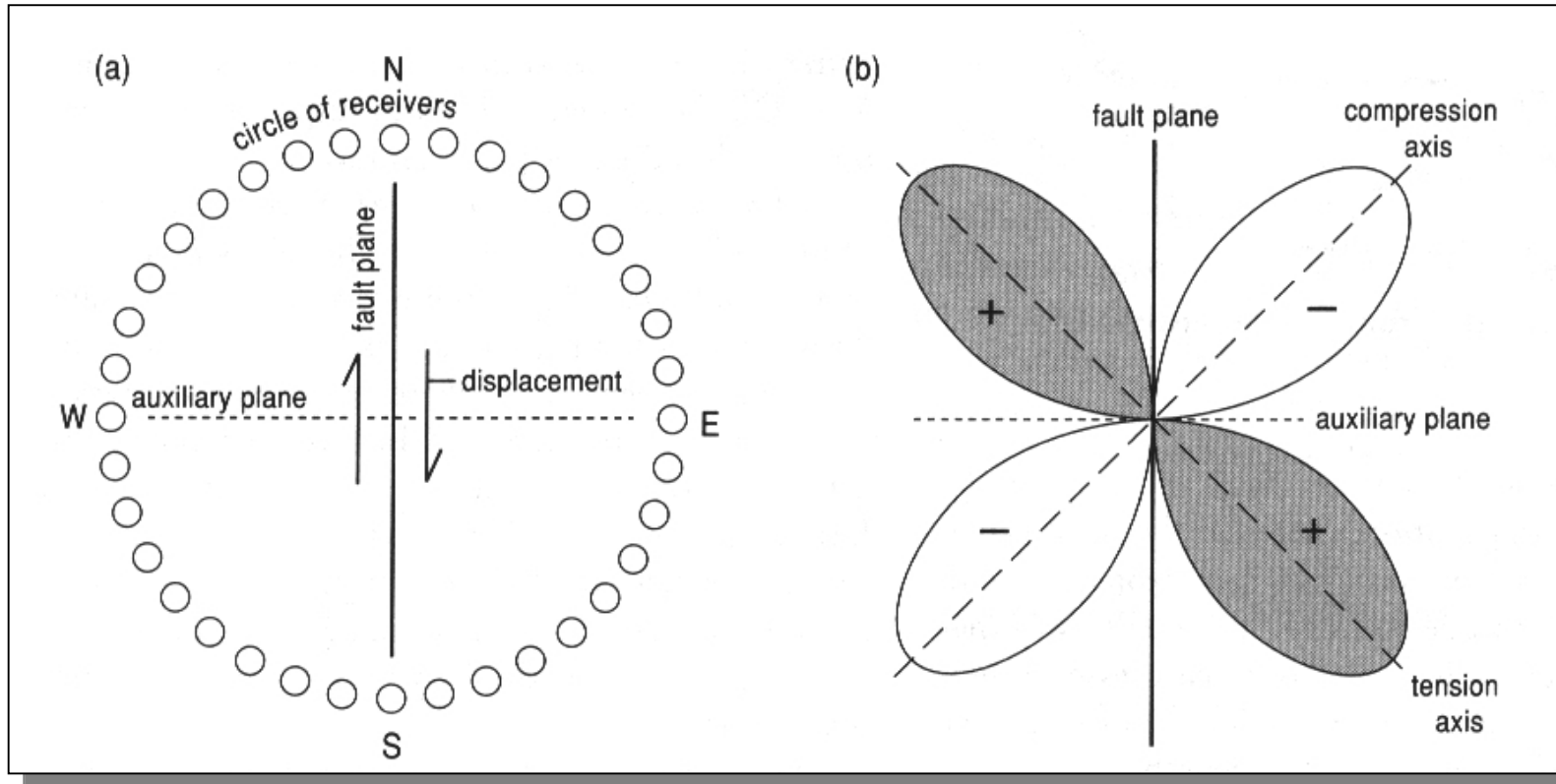

The basic physical model for a source is two fault planes slipping in opposite directions



# The ambiguity

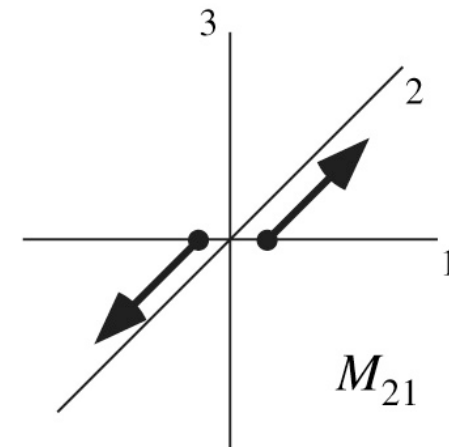
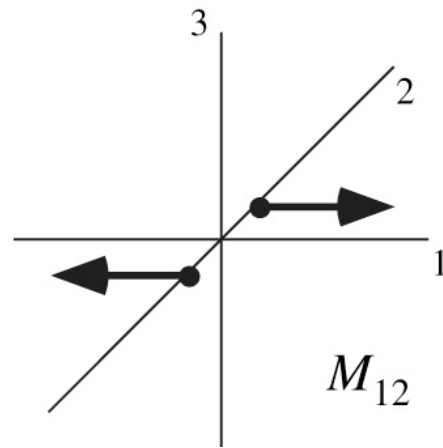
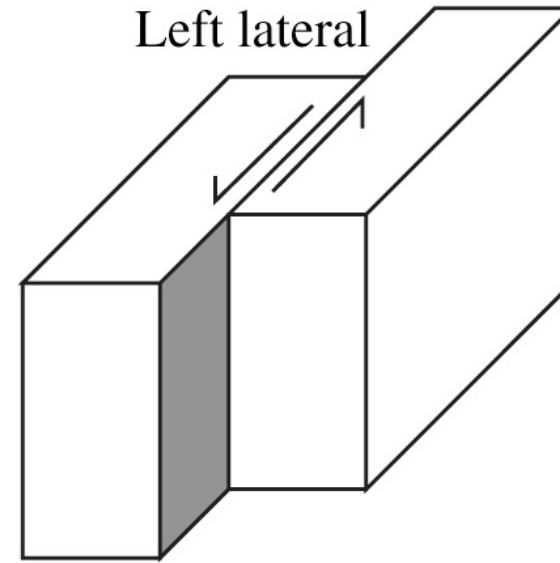
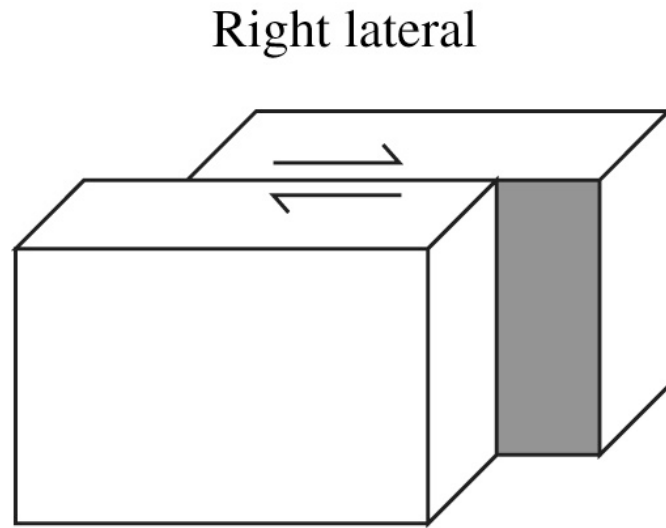

Same moment tensor, same radiation pattern!

# Possible double couples – Moment tensor

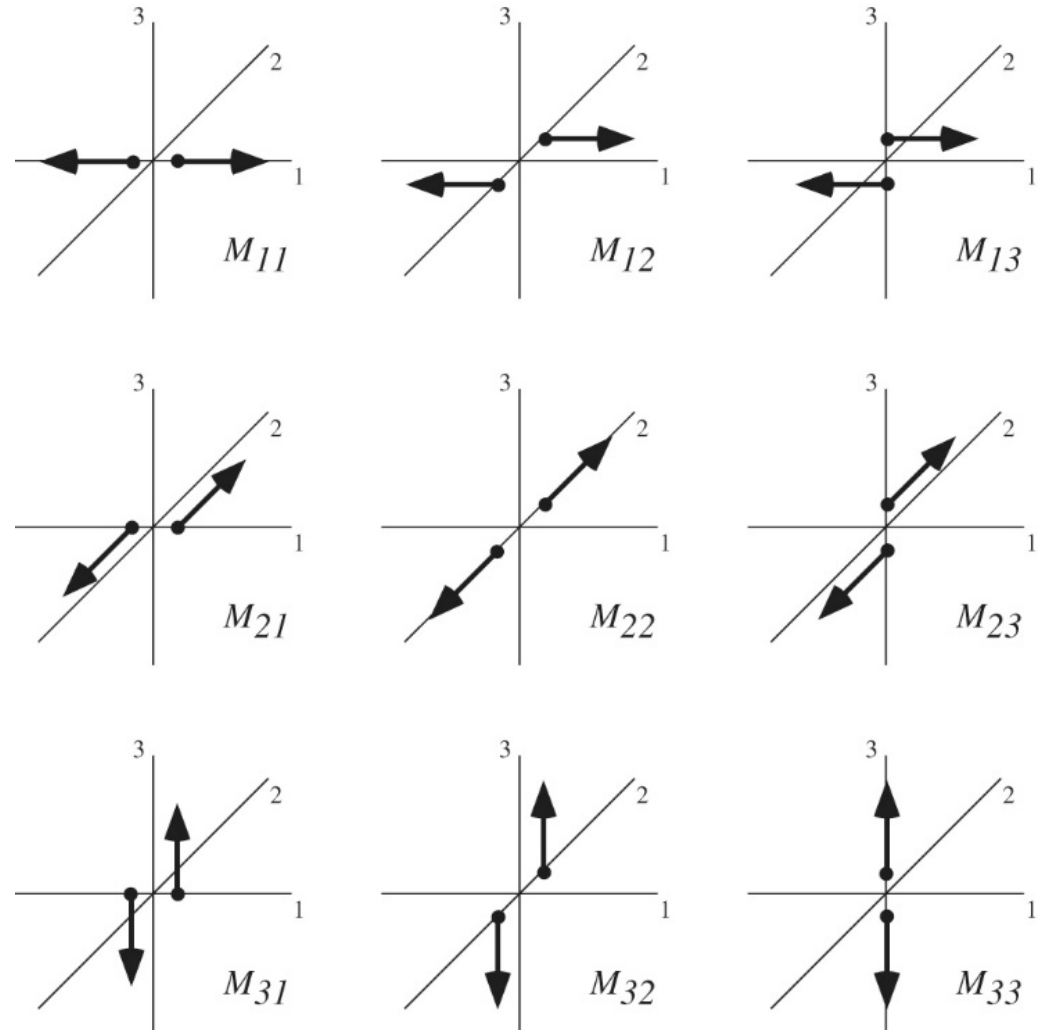

# Radiation pattern

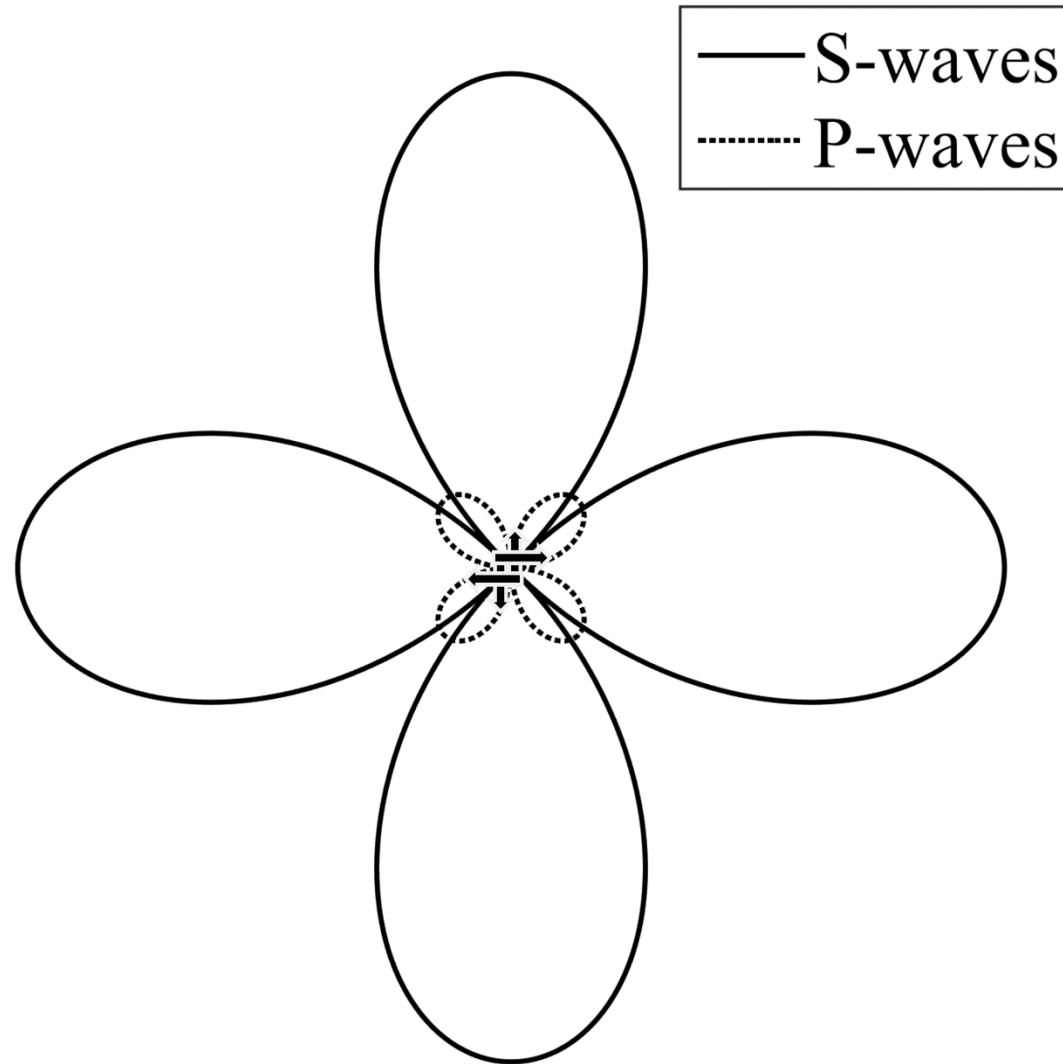

# Wavefield explosion

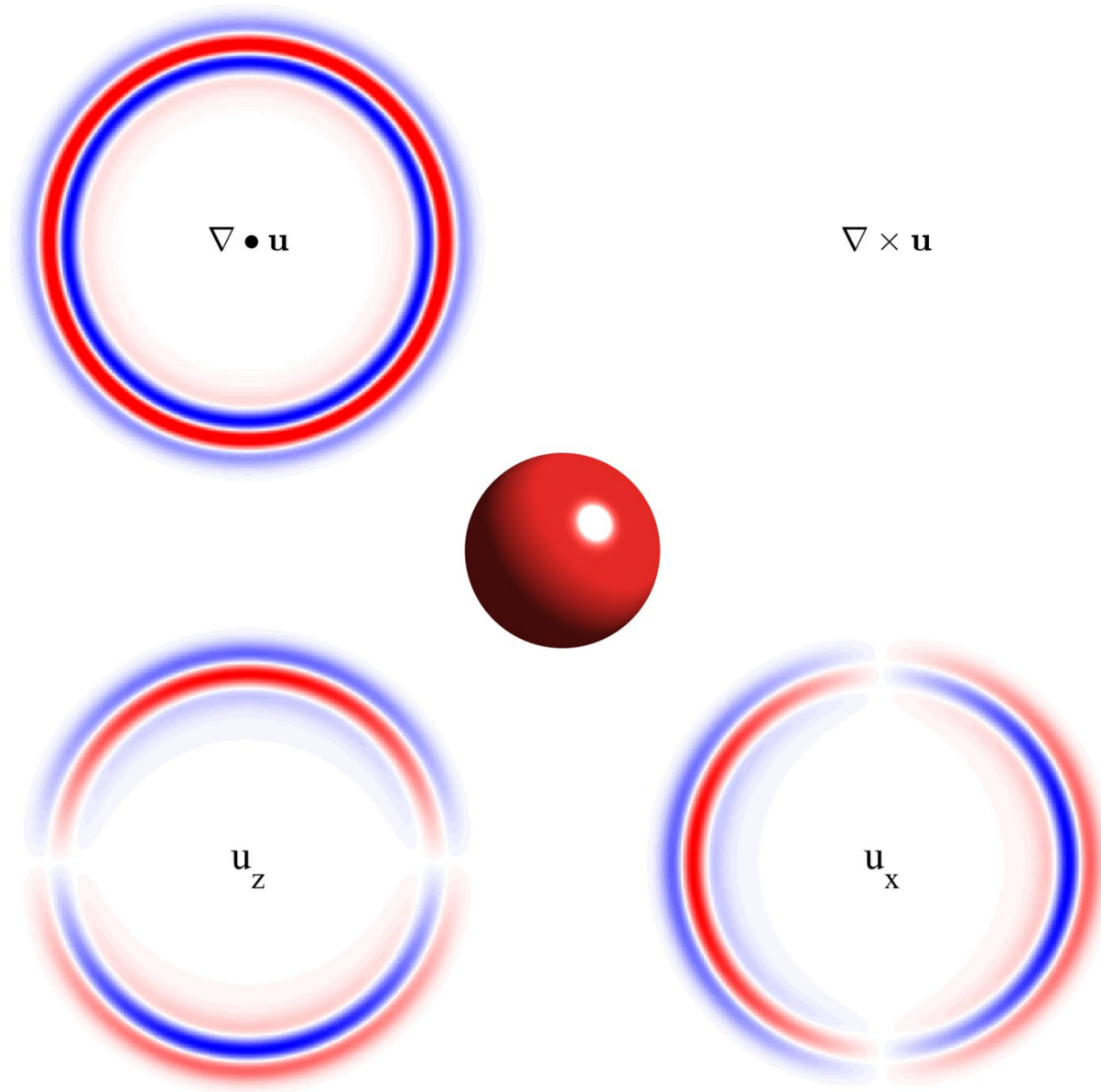

# Wavefield double couple

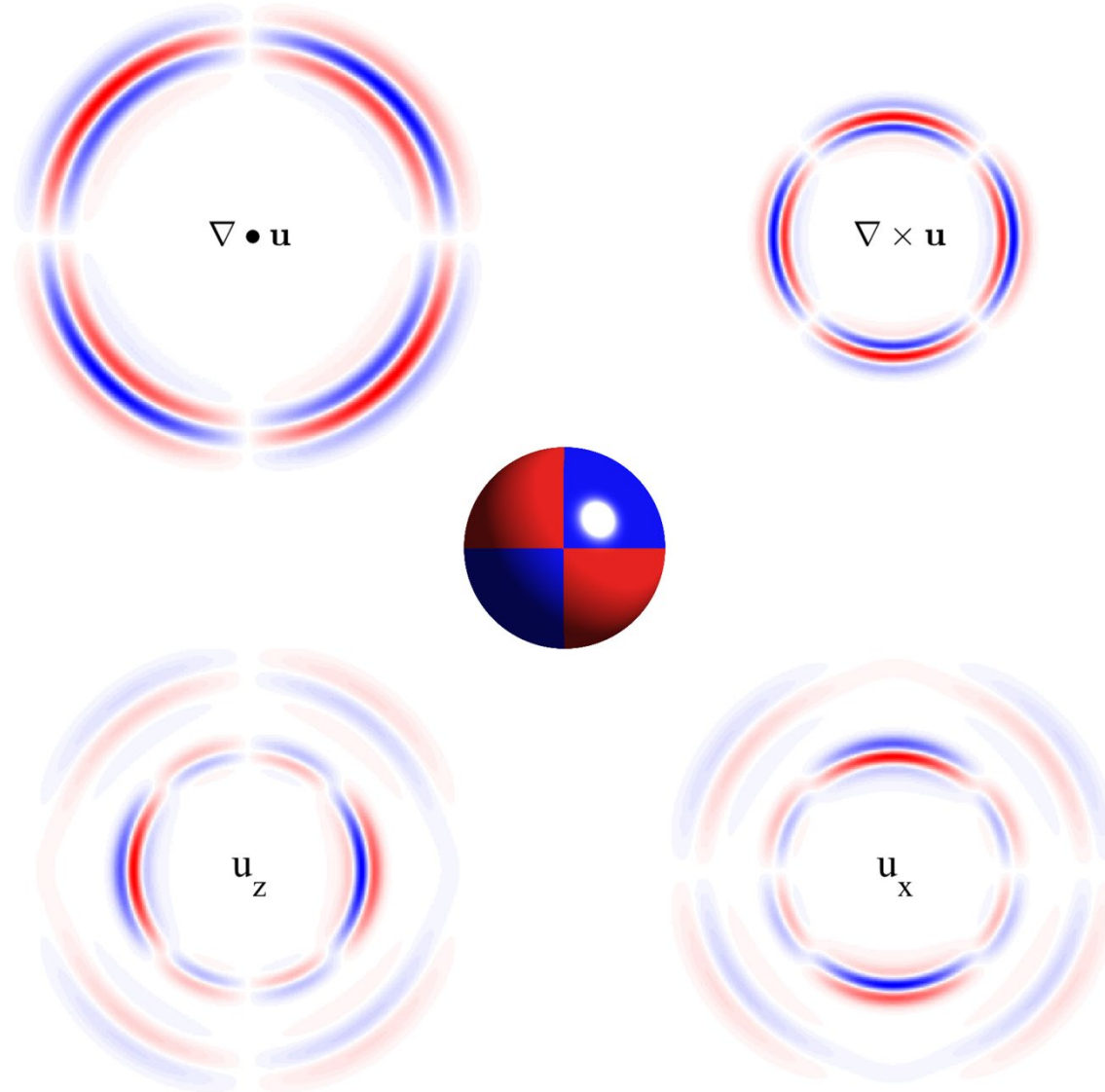

# Radiation pattern – first motions

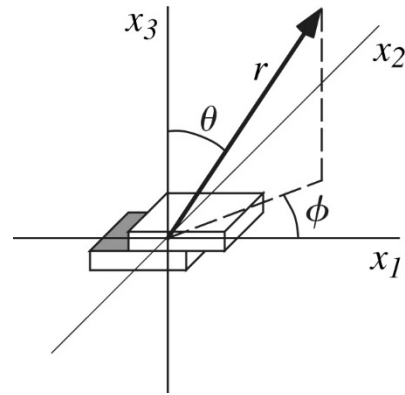
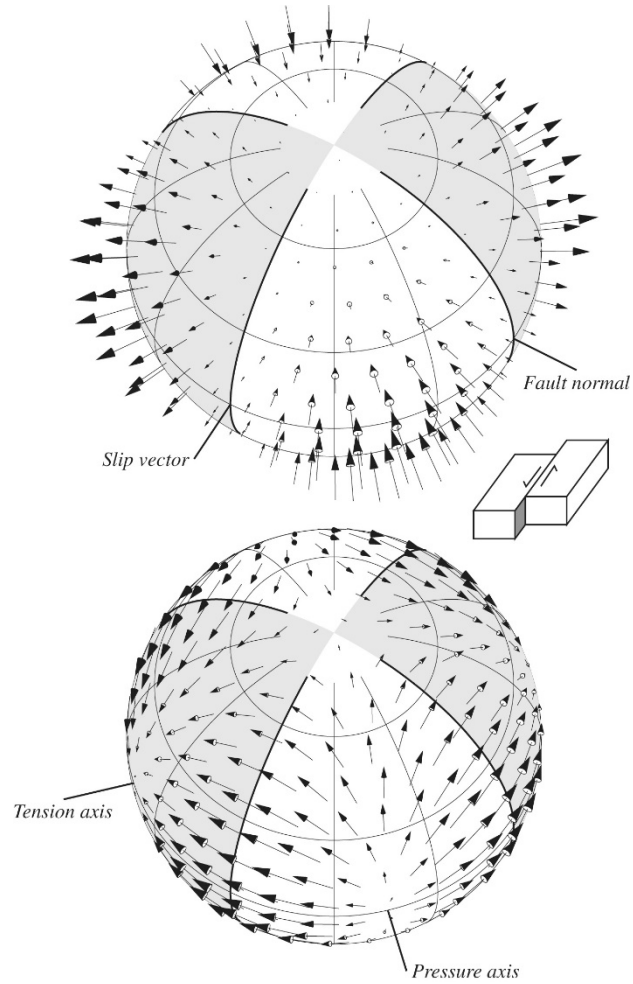

Far field P – blue  
Far field S – red

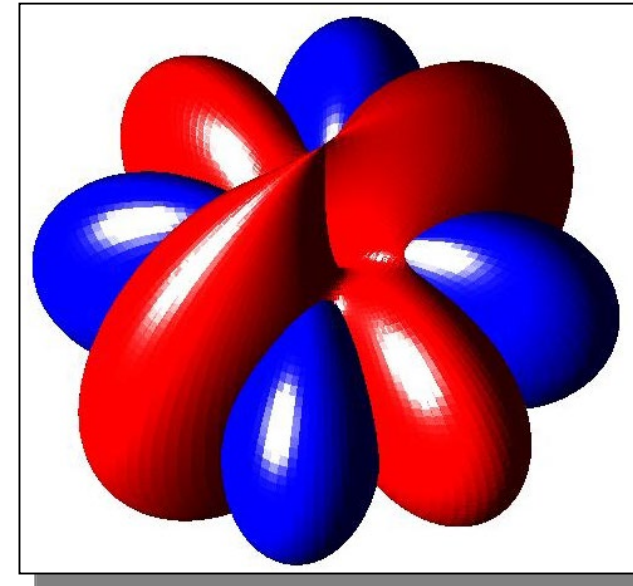
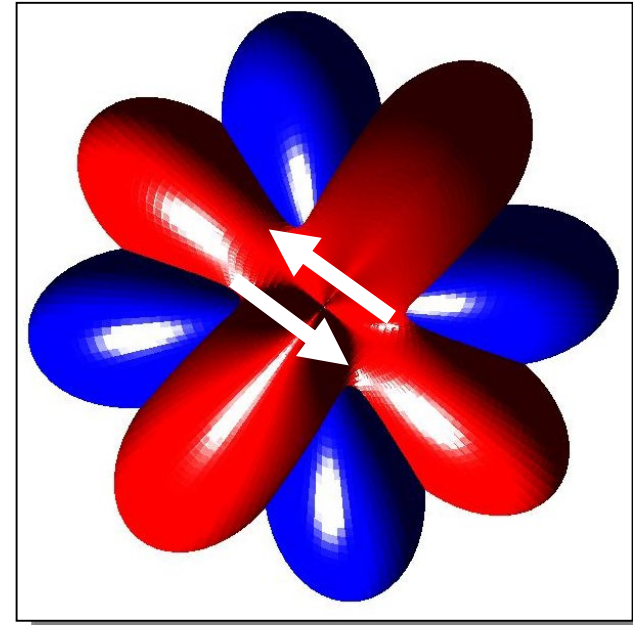

# Velocity seismograms-M6.5 point source

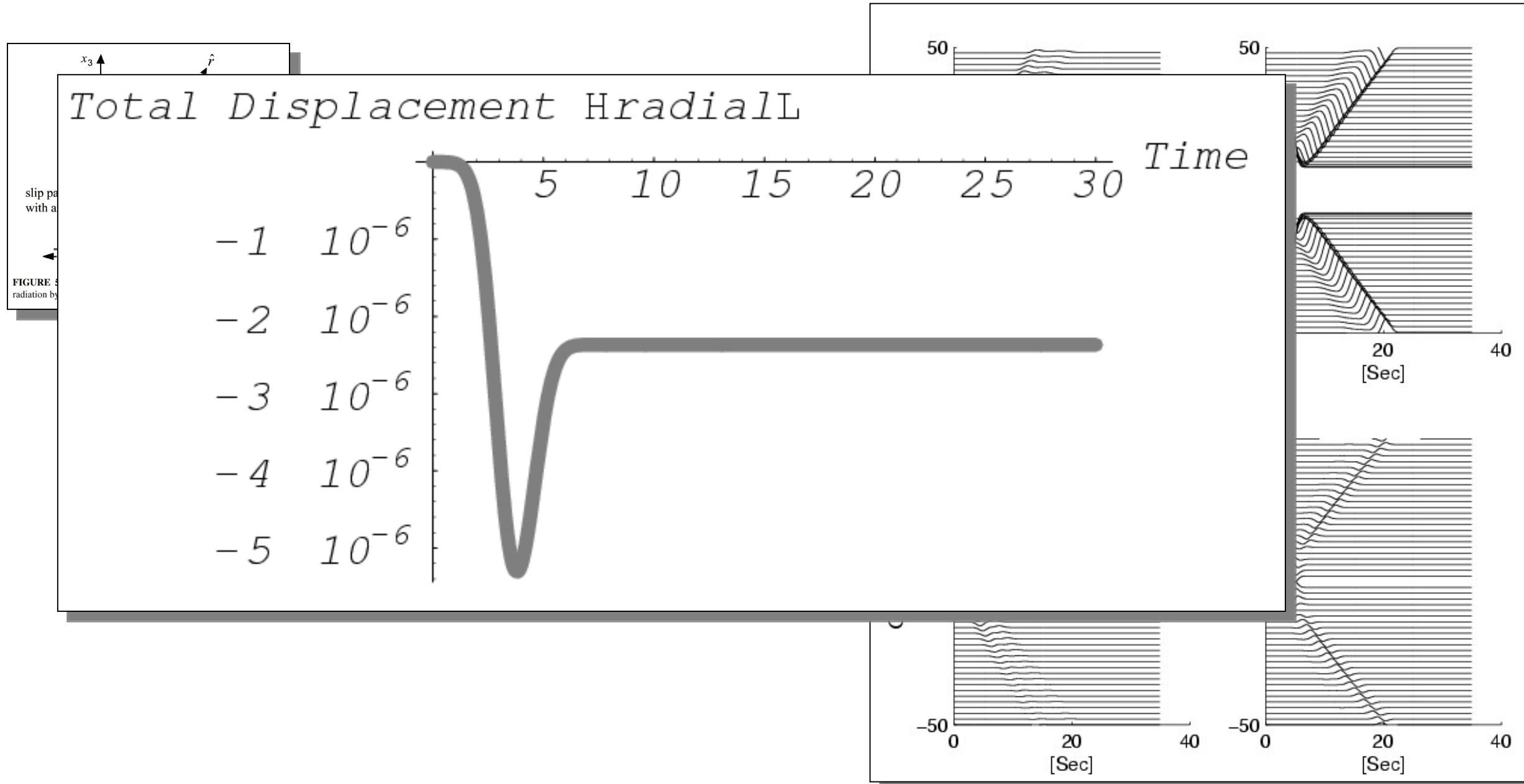

Wie kann ich die Quellgeometrie aus  
Beobachtungen ableiten?



# Radiation from shear dislocation – Moment tensor inversion

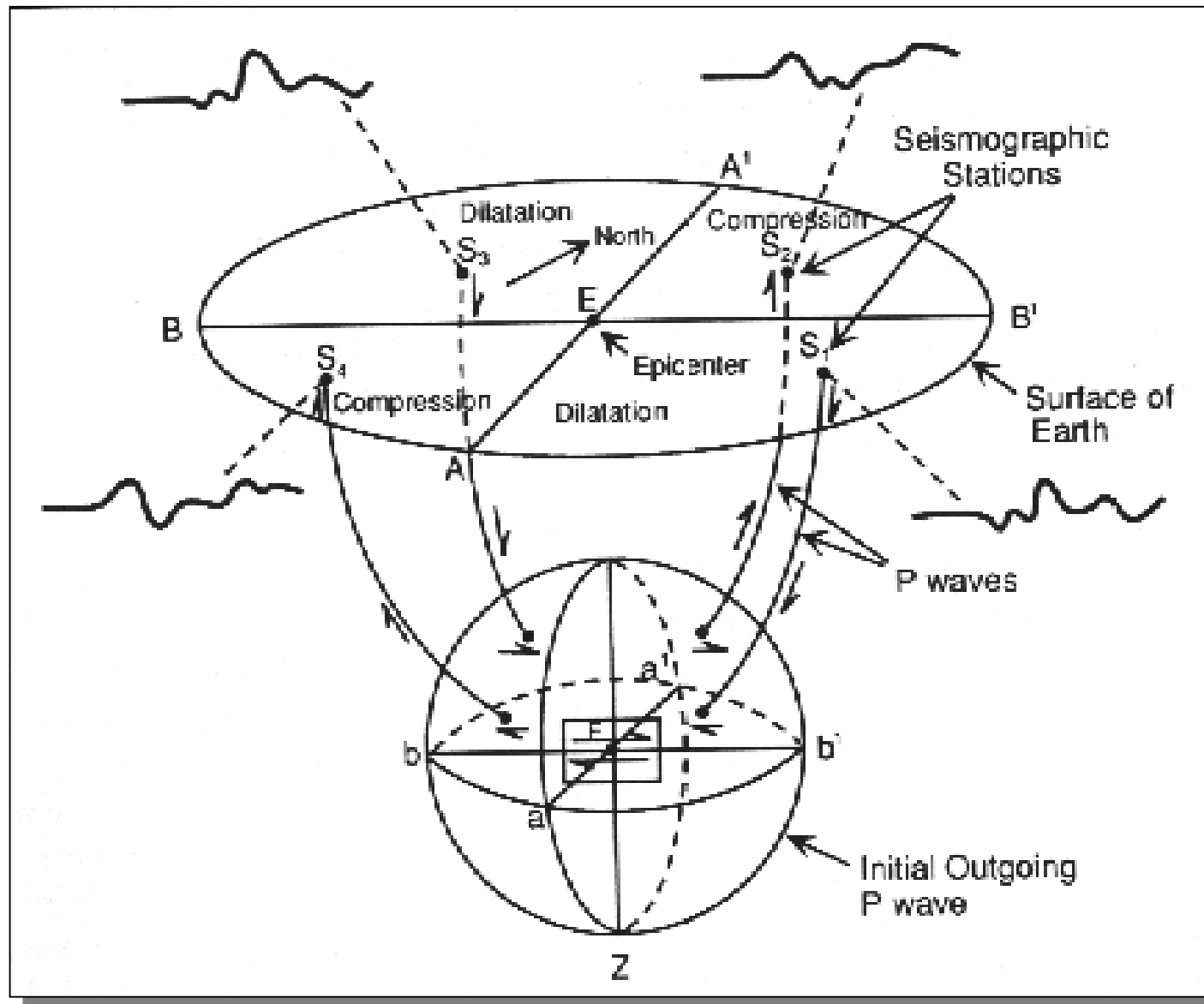

First motion of P waves at seismometers in various directions.

The polarities of the observed motion is used to determine the point source characteristics.

# Beach balls and Fault types

Strike Slip

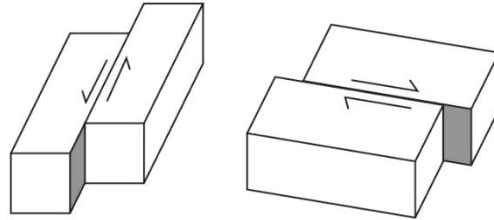
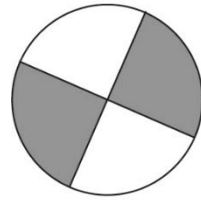

Normal

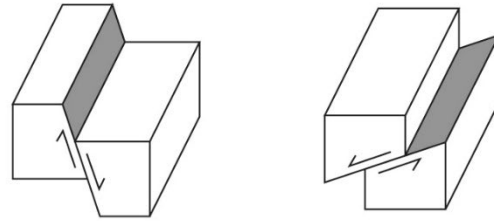
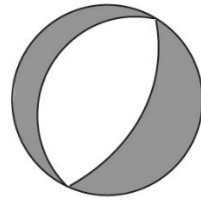

Reverse

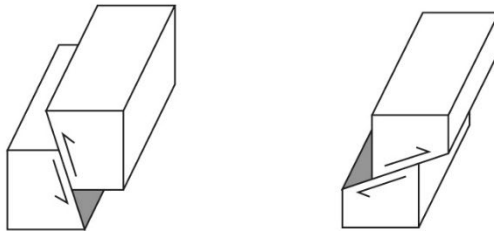
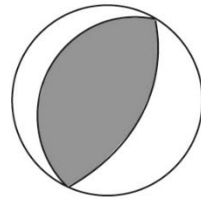

Oblique

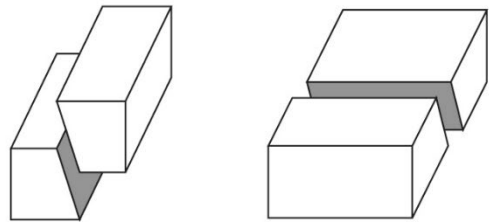
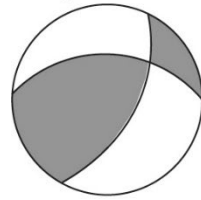

Basis fault types and their appearance in the focal mechanisms. Dark regions indicate compressional P-wave motion.

# Beachball in California

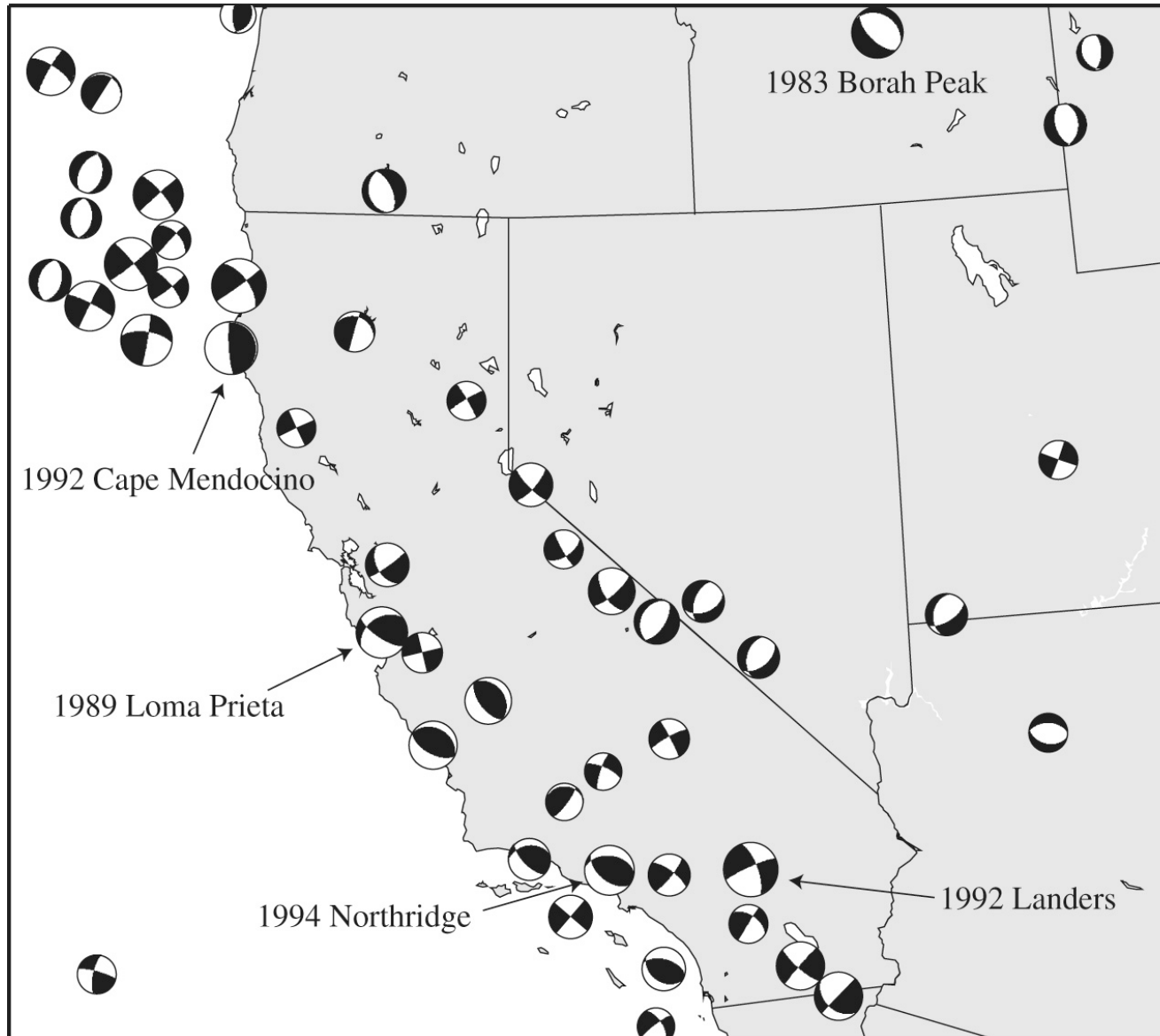

# Big earthquakes

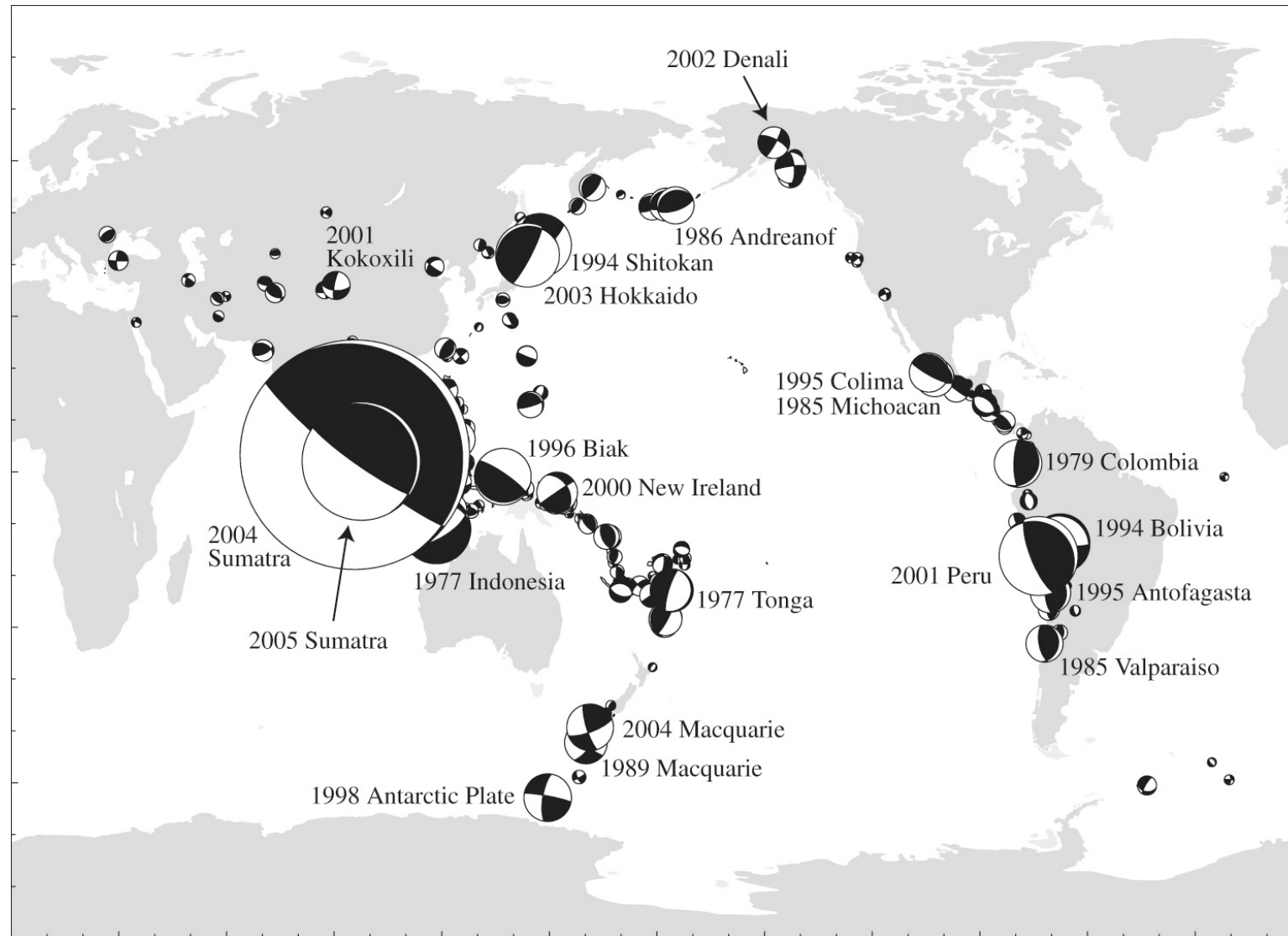

# Beachballs - Himalaya

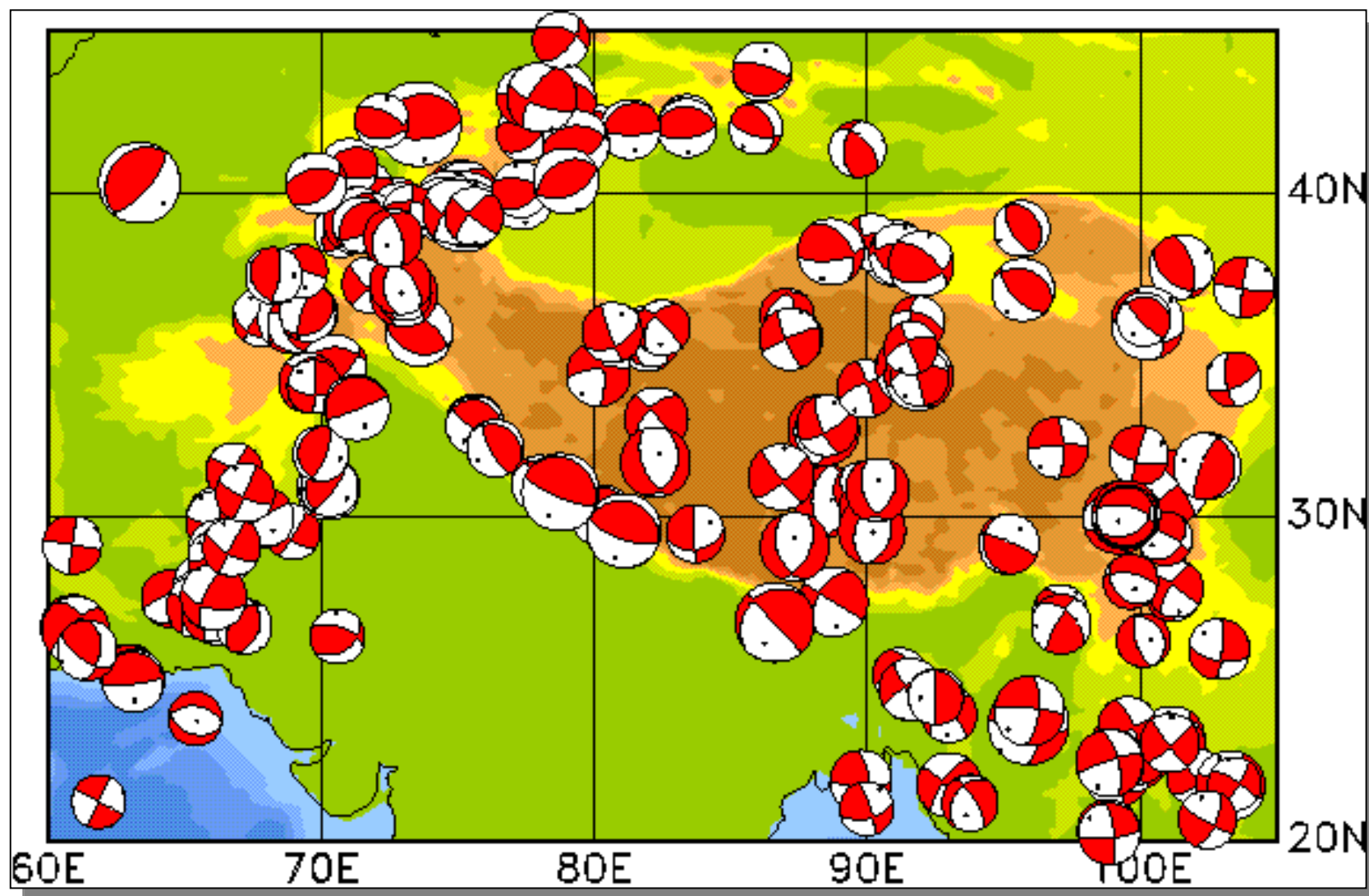

# Beachballs - global

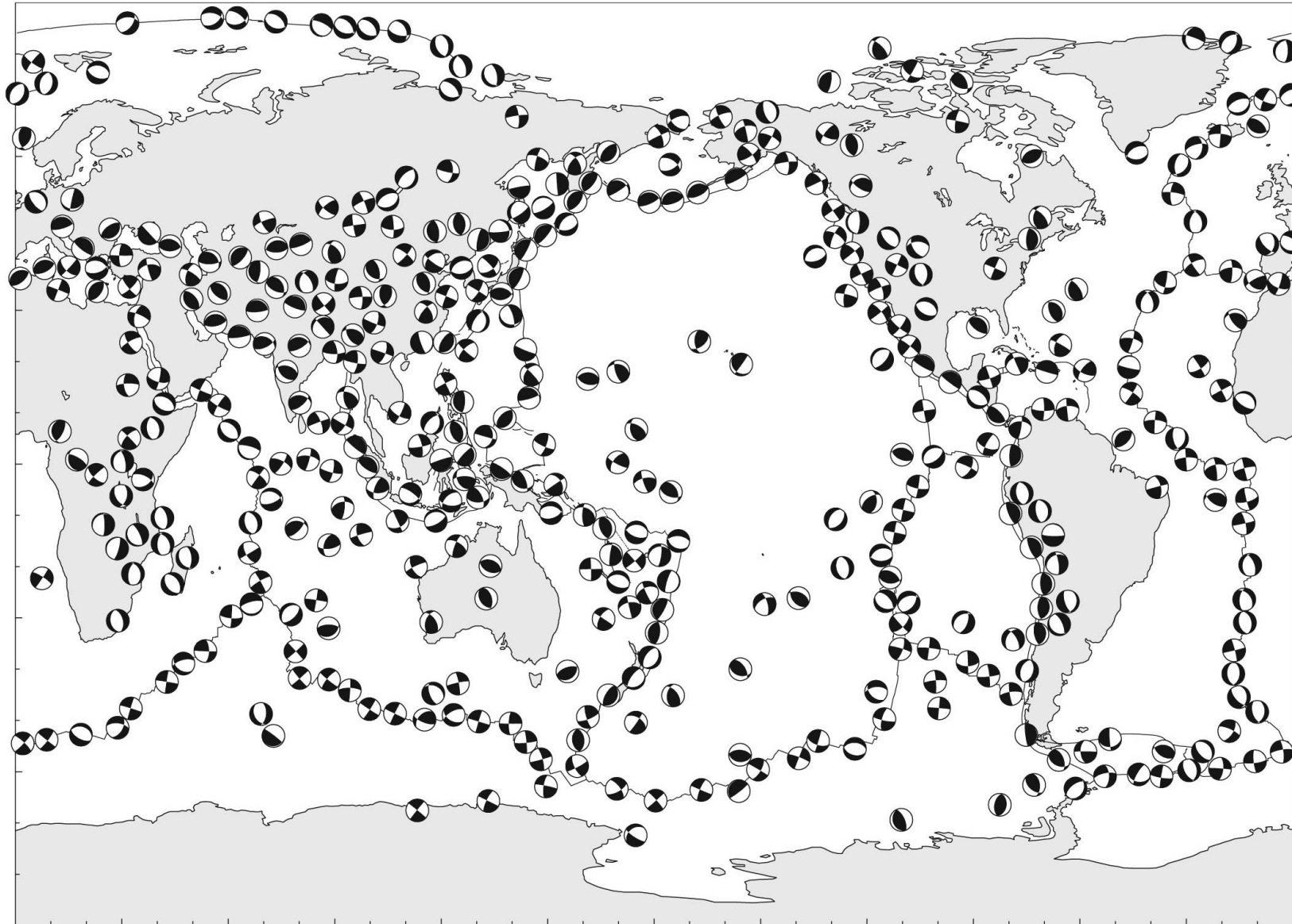

# Beachballs - Iceland

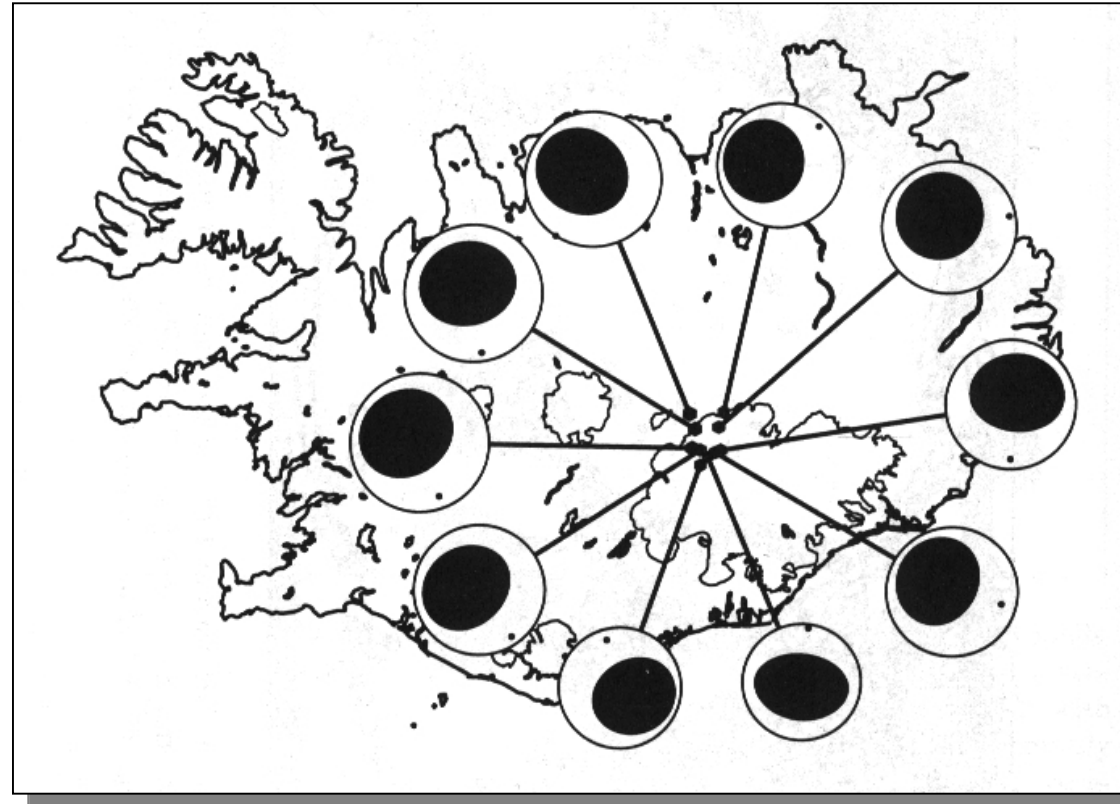

*Fried eggs*: simultaneous vertical extension and horizontal compression

Was ist mit GROSSEN Erdbeben?



# Source kinematics

Point source characteristics (source moment tensor, rise time, source moment, rupture dimensions) give us some estimate on what happened at the fault. However we need to take a closer look. We are interested in the space-time evolution of the rupture.

Here is the fundamental concept:

The recorded seismic waves are a superpositions of many individual double-couple point sources.

This leads to the problem of estimating this space-time behavior from observed (near fault) seismograms. The result is a **kinematic** description of the source.

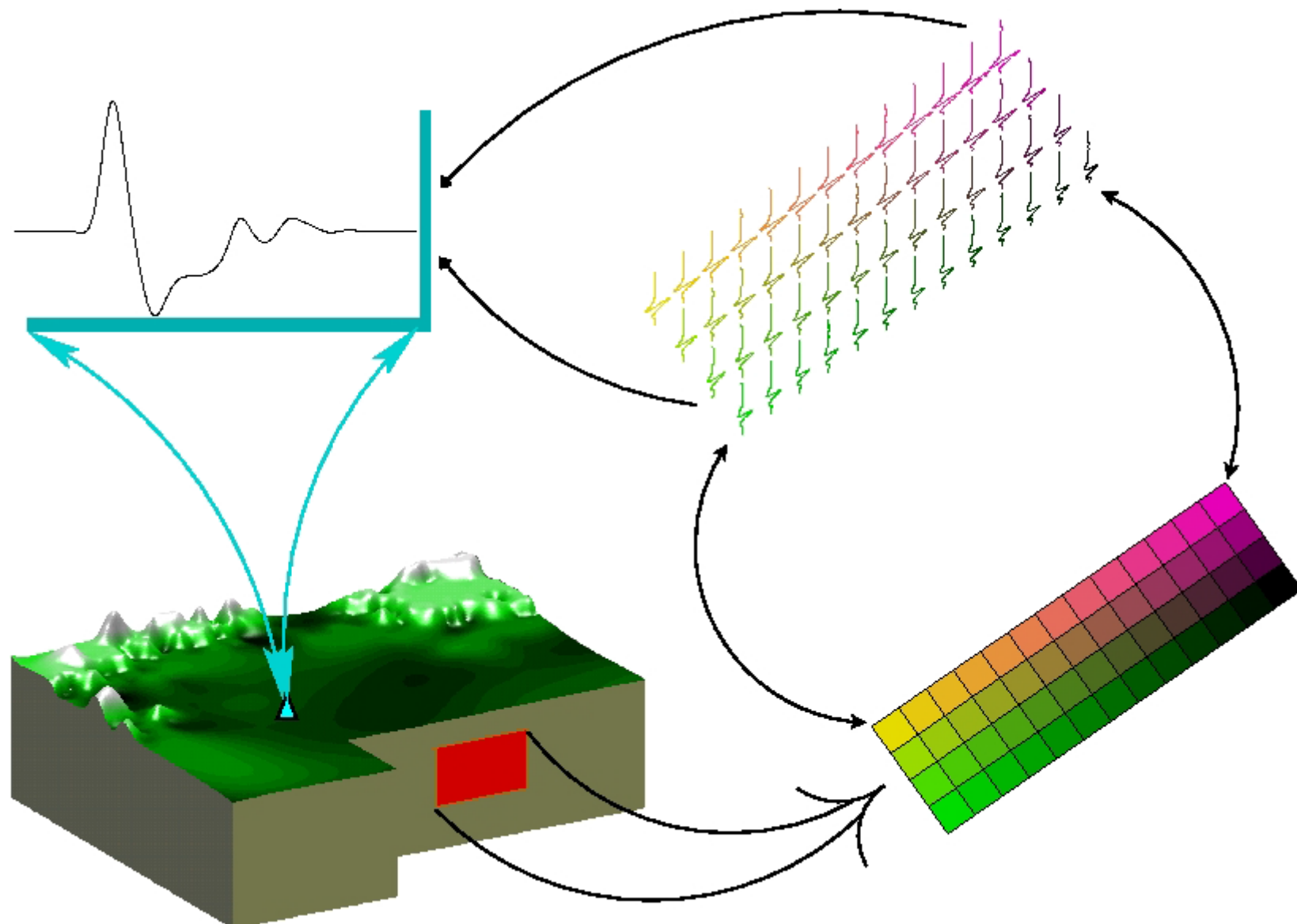

# Dynamic rupture

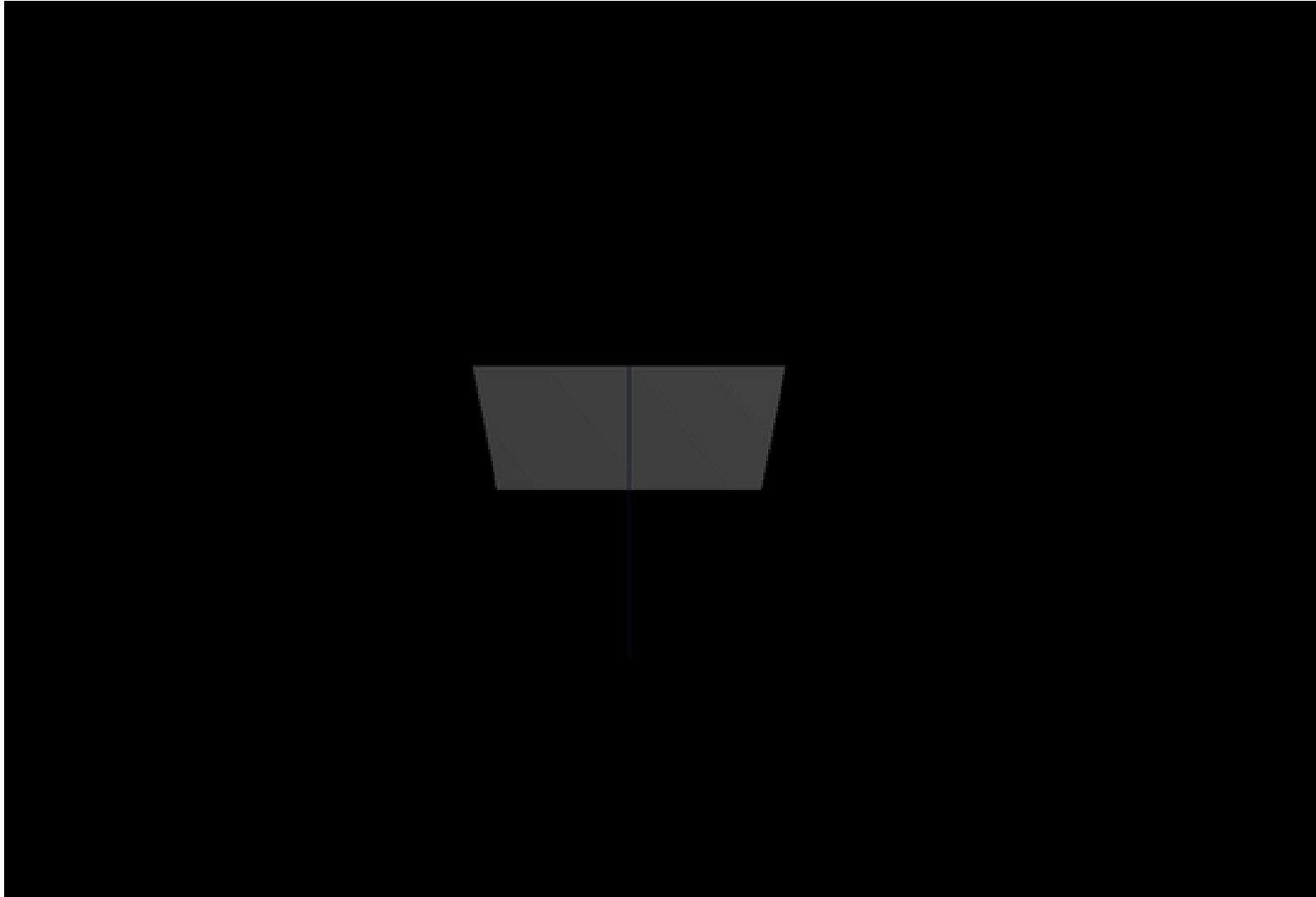

# Source directivity

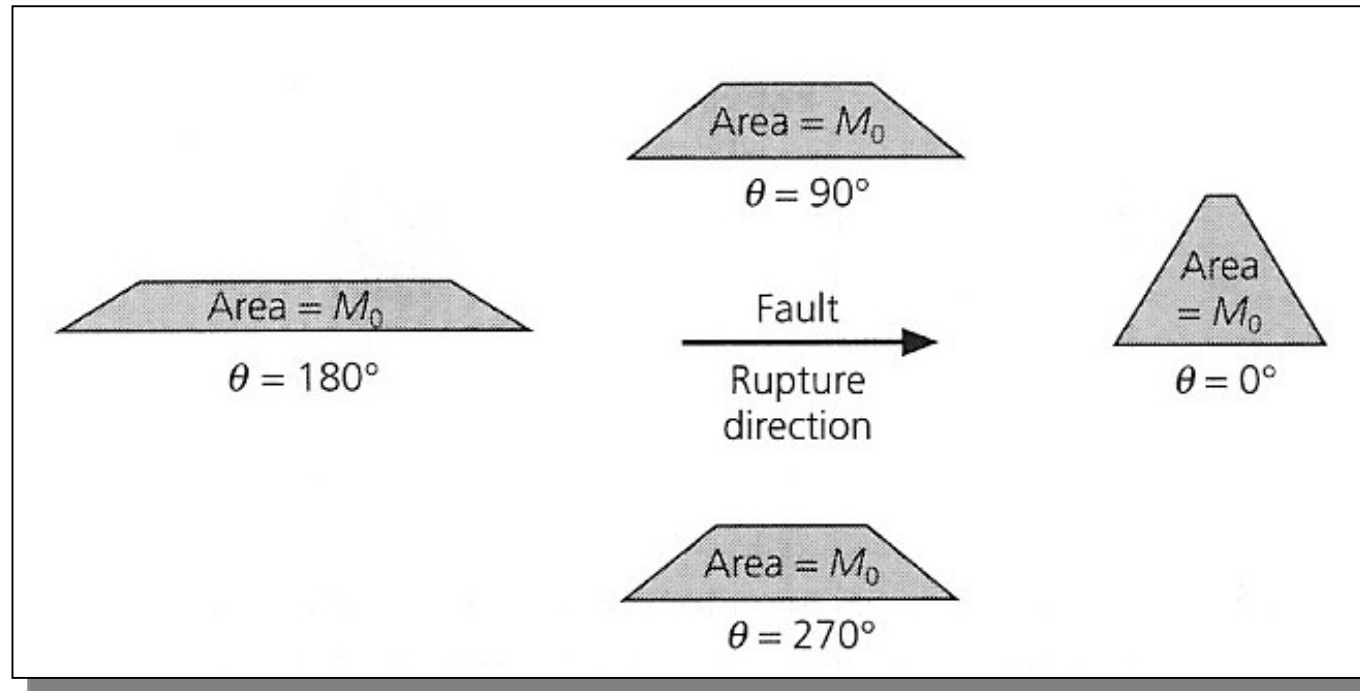

The energy radiation becomes strongly anisotropic (Doppler effect). In the direction of rupture propagation the energy arrives within a short time window.

# M9 Japan 2011

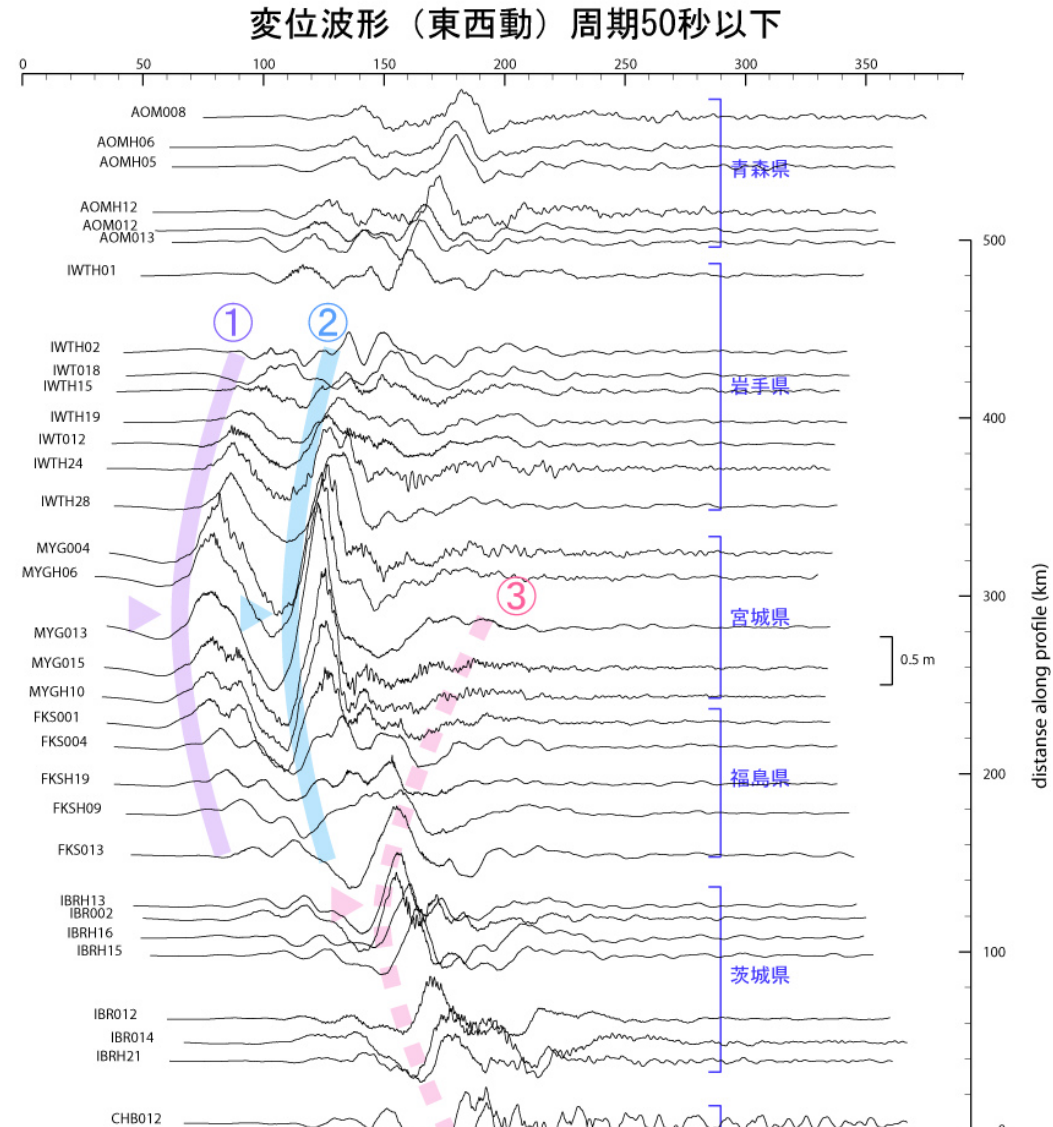
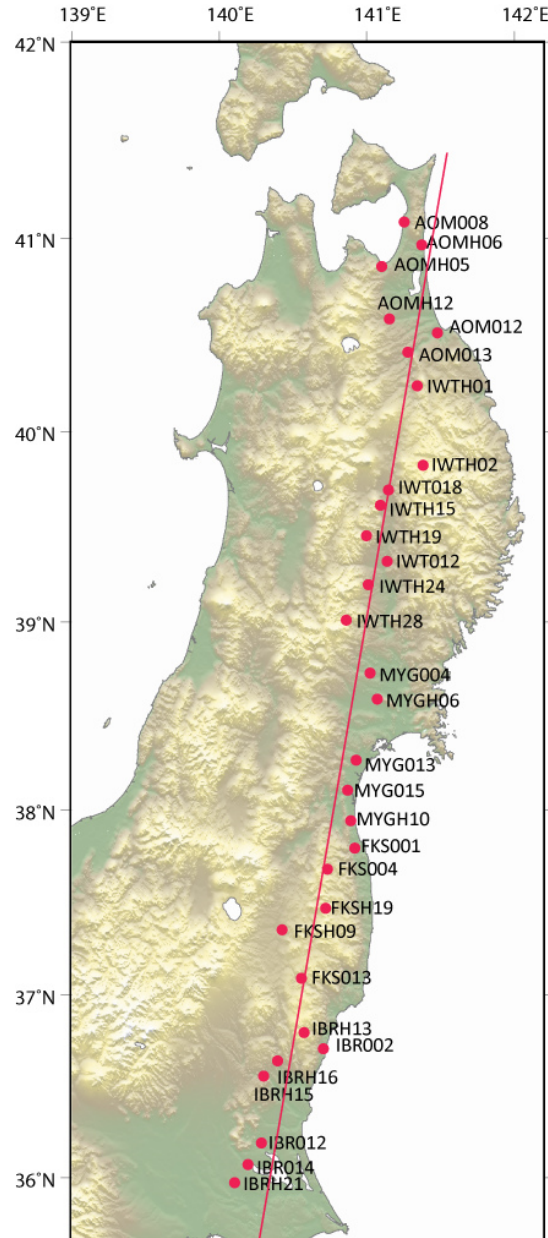

# Horizontal displacements

Beobachtete Verschiebungen  
(Simons, Science,  
2011)

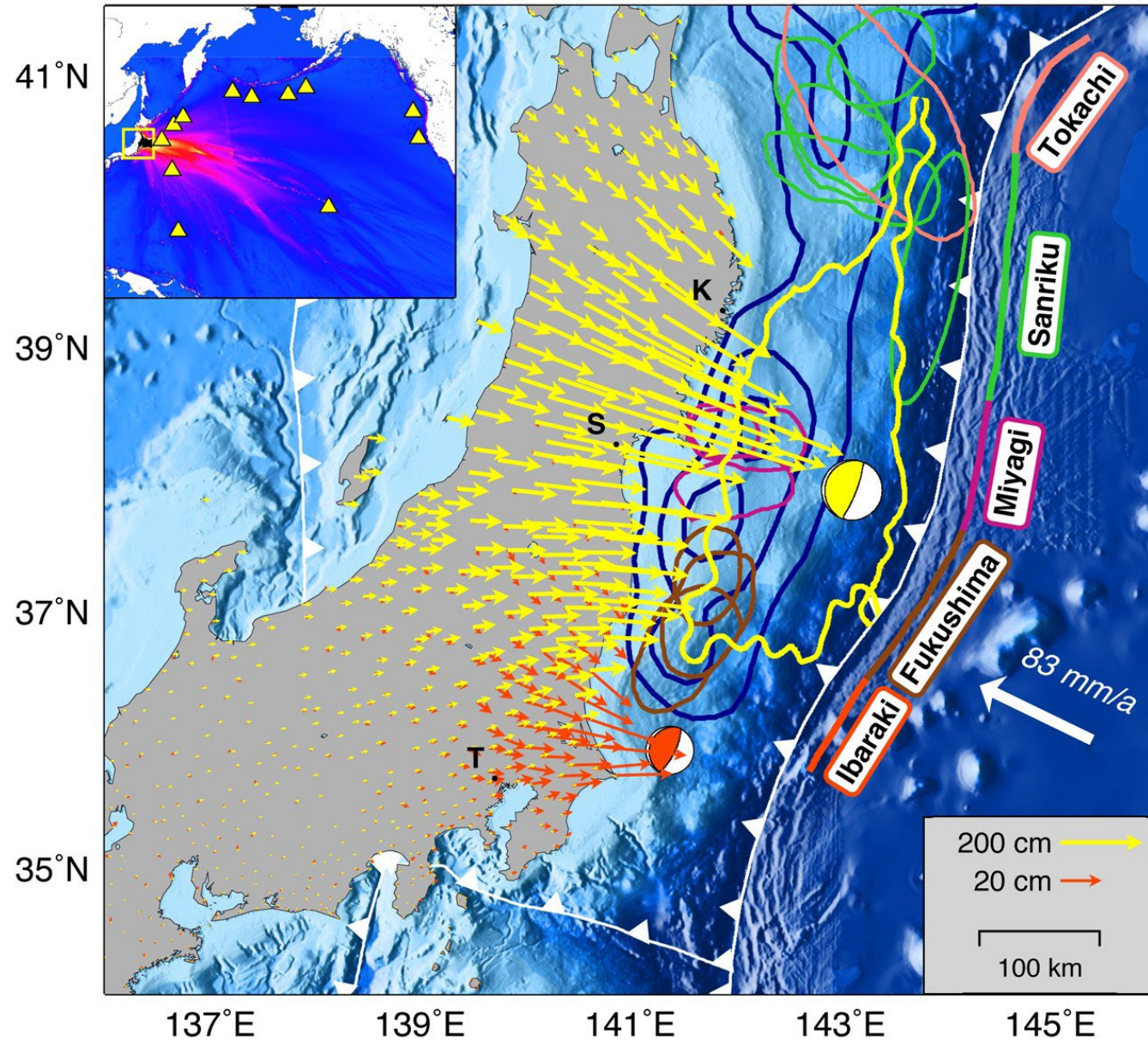

# Vertical displacements

Beobachtete Verschiebungen  
(Simons, Science,  
2011)

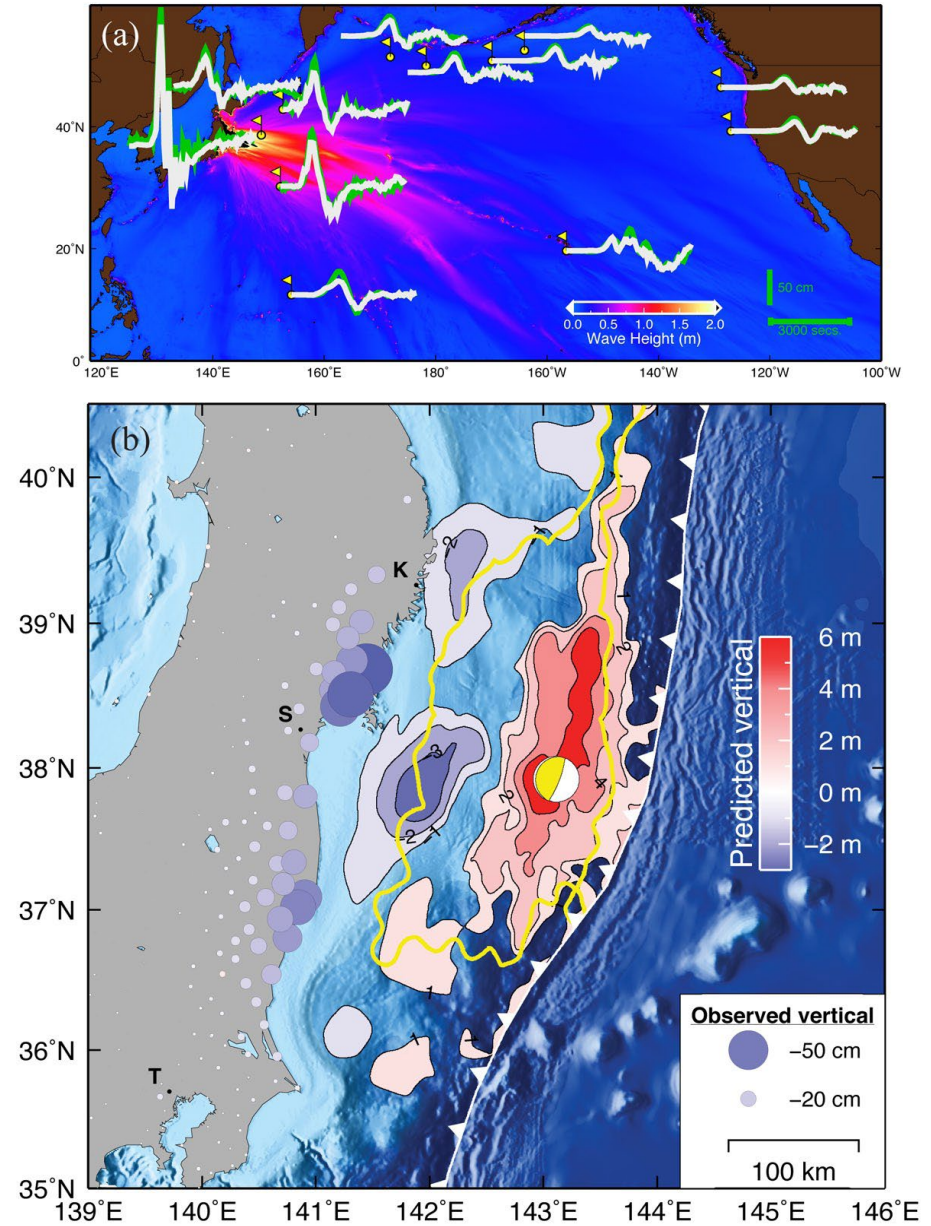

# 50m slip on the fault!

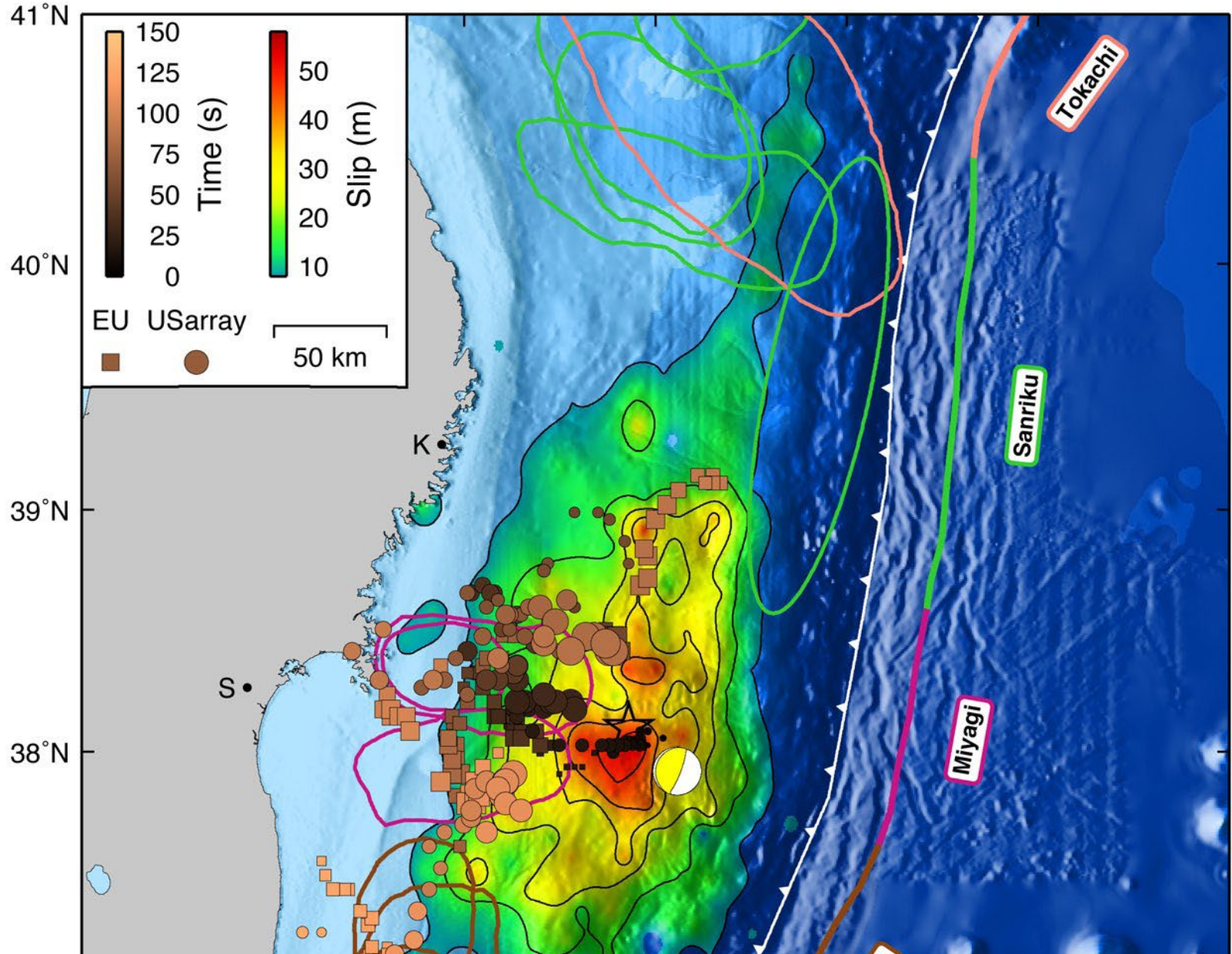



# Source kinematics

Slip rate as a function of various fault conditions (Landers earthquake)

Source: K Olsen, UCSB

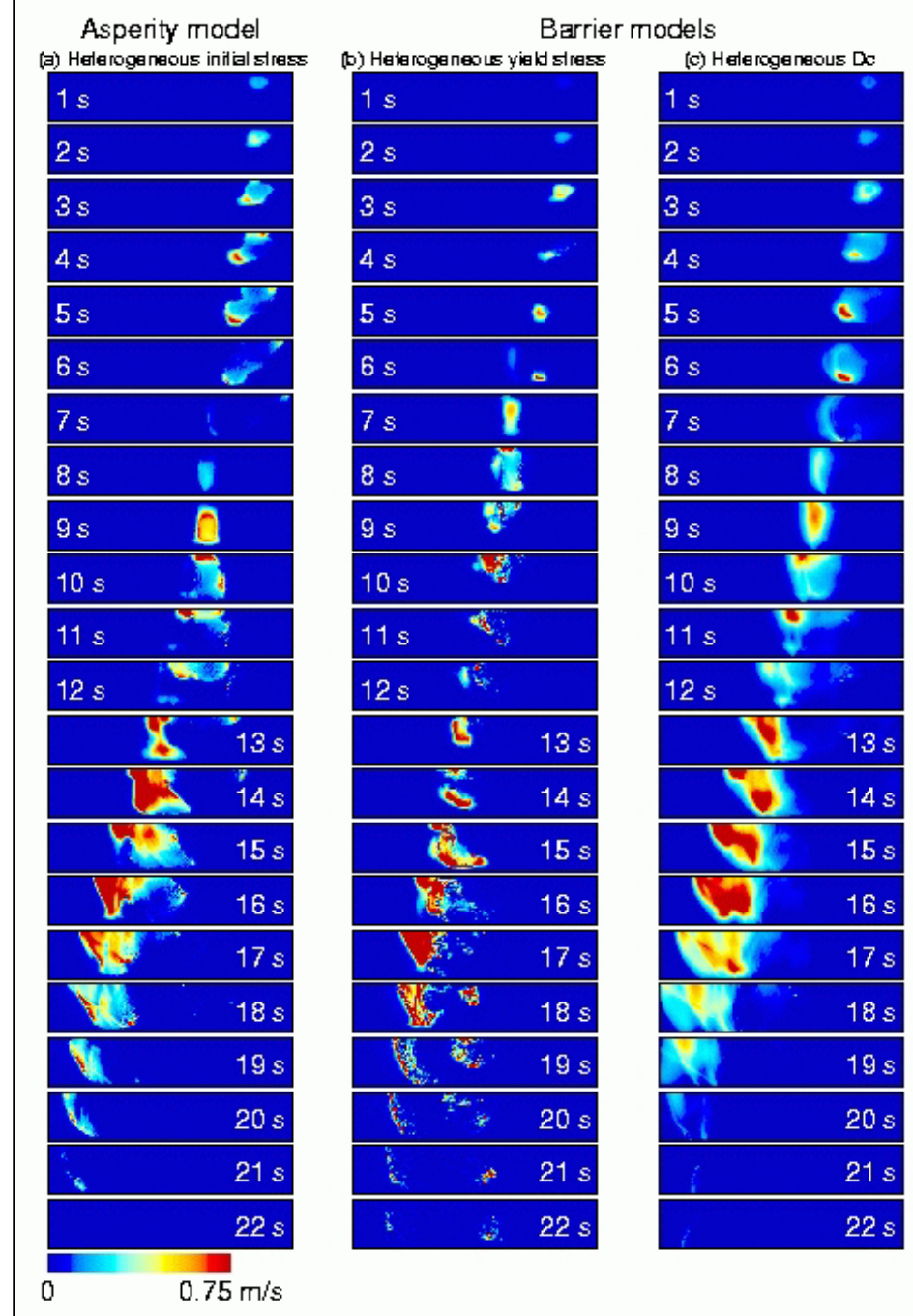

# Source kinematics

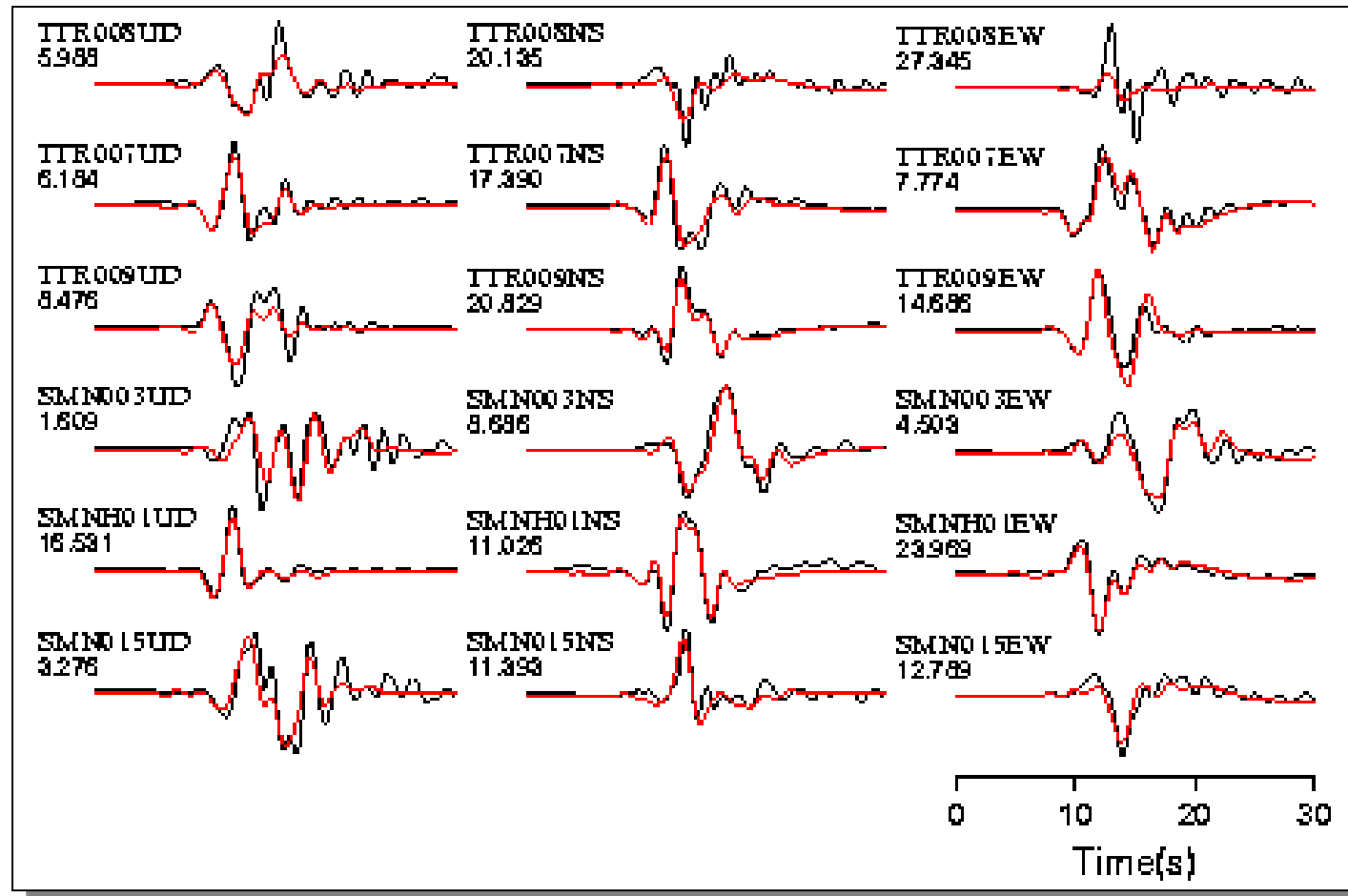

Fit between observations (red) and finite fault simulations (black)

# The California Event (D. Dreger, Berkeley)

July 6, 2019 Mw6.9 ( $M_0=3.14e+26$  dyne cm)

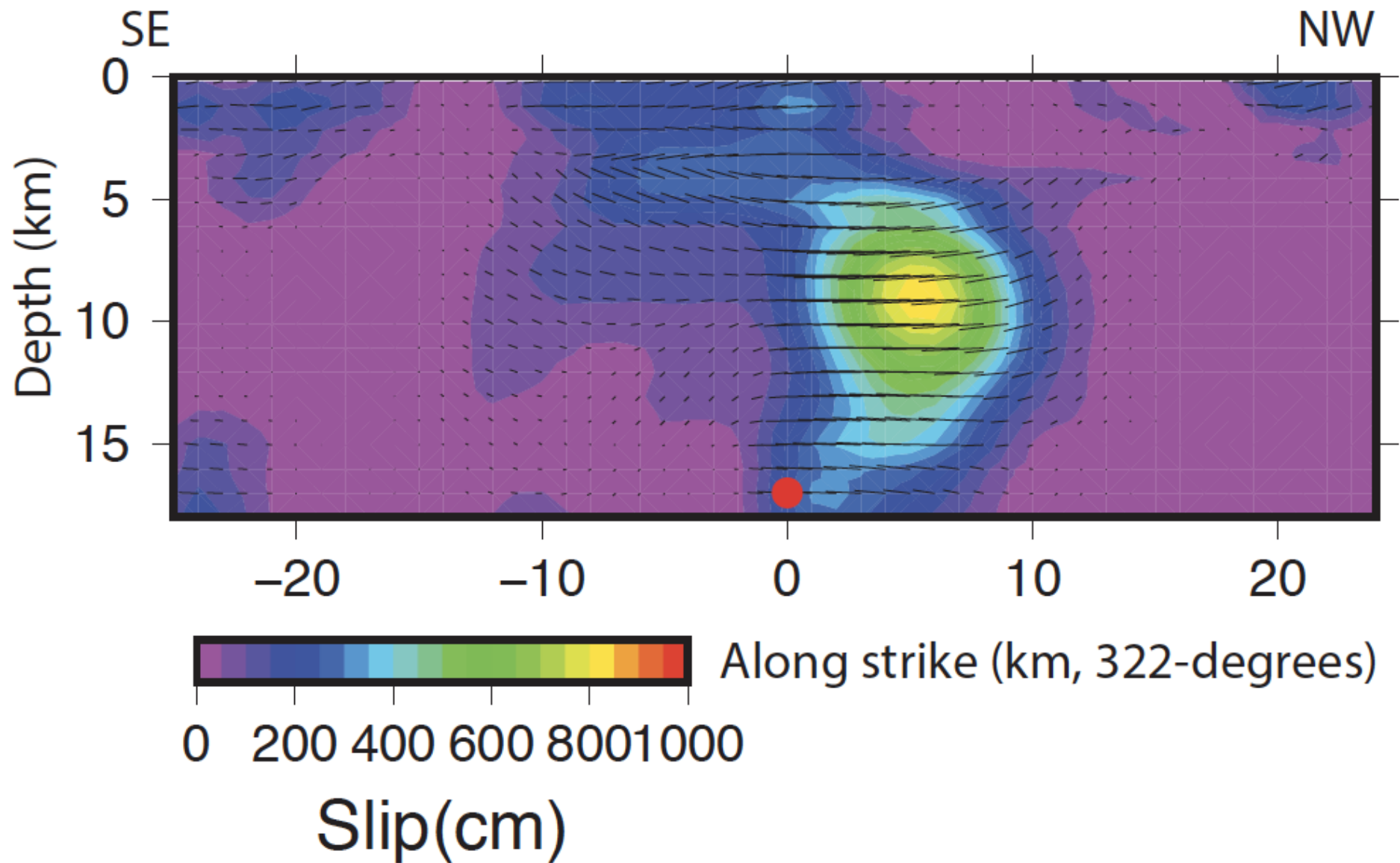

# Energie von Erdbeben

## Magnitude

# Seismic moment

Seismologists measure the size of an earthquake using the concept of seismic moment. It is defined as the force times the distance from the center of rotation (torque). The moment can be expressed surprisingly simple as:

$$M_0 = \mu A d$$

$M_0$  seismic moment

$\mu$  Rigidity

$A$  fault area

$d$  slip/displacement

# Seismic moment

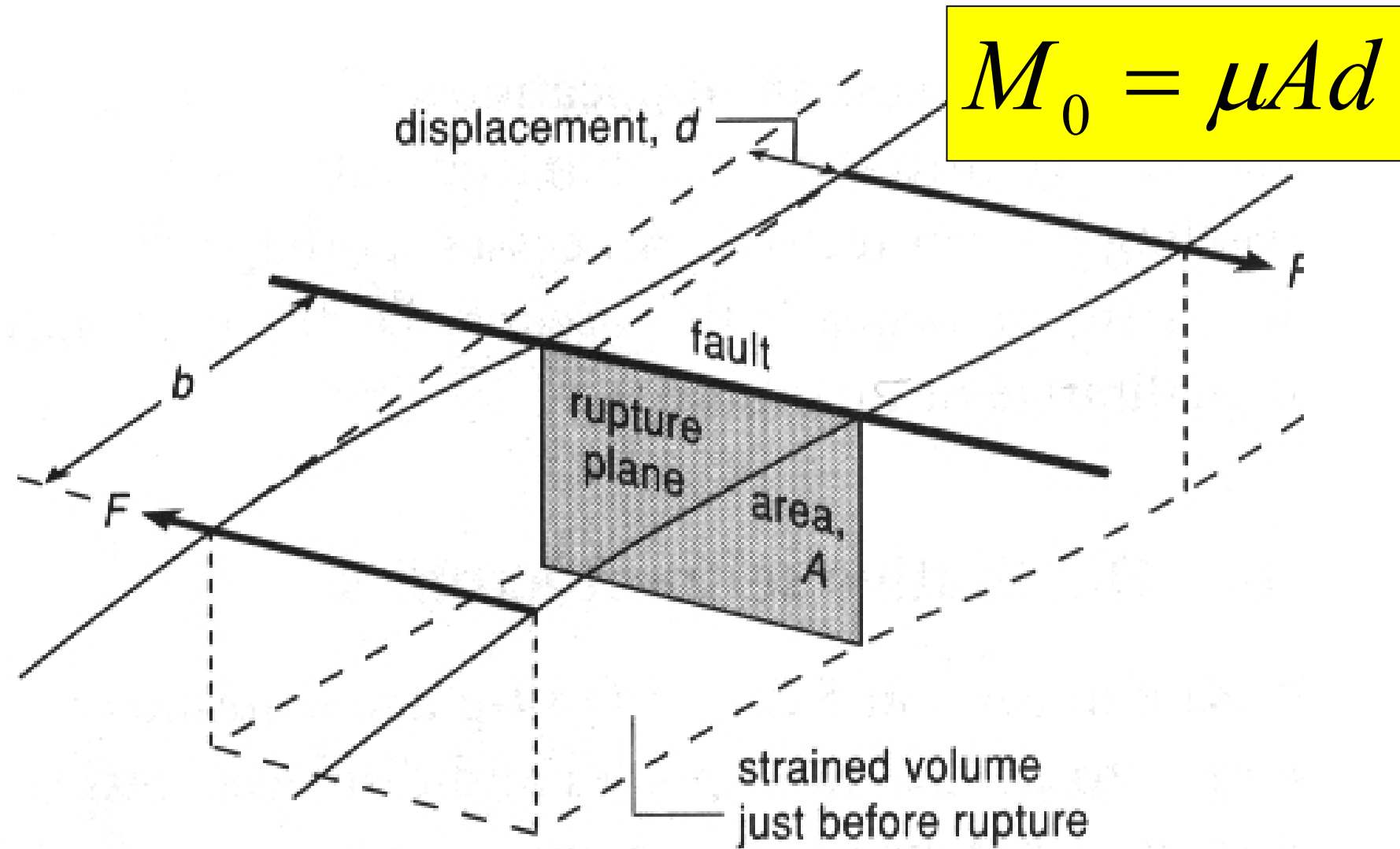

# Seismic moment

$$M_0 = \mu A d$$

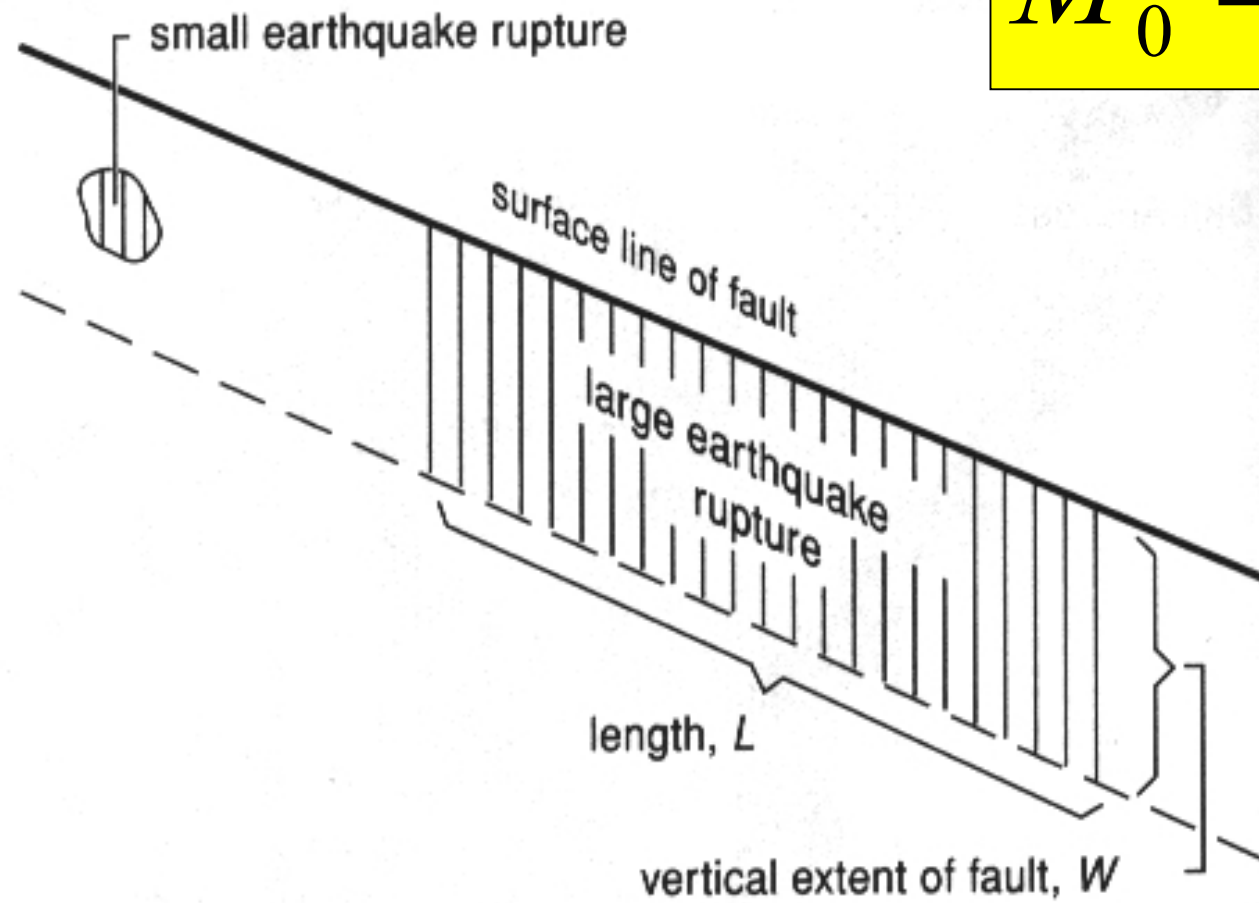

# Seismic moment

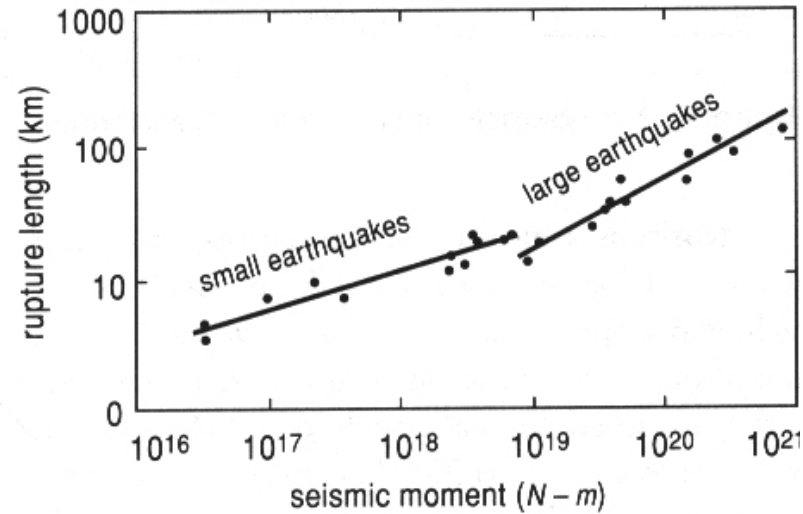

$$M_0 = \mu A d$$

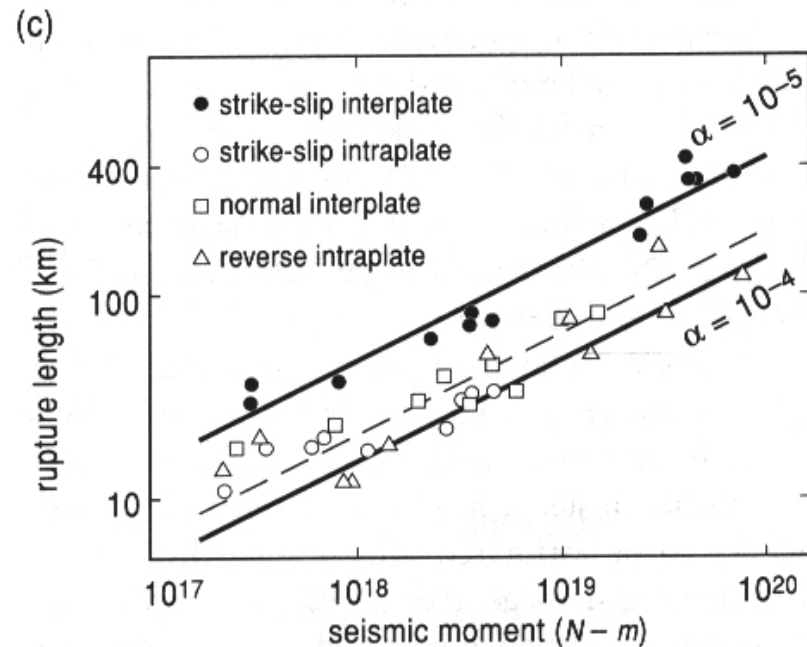

There are differences in the scaling of large and small earthquakes



# Magnitude Scales - Richter

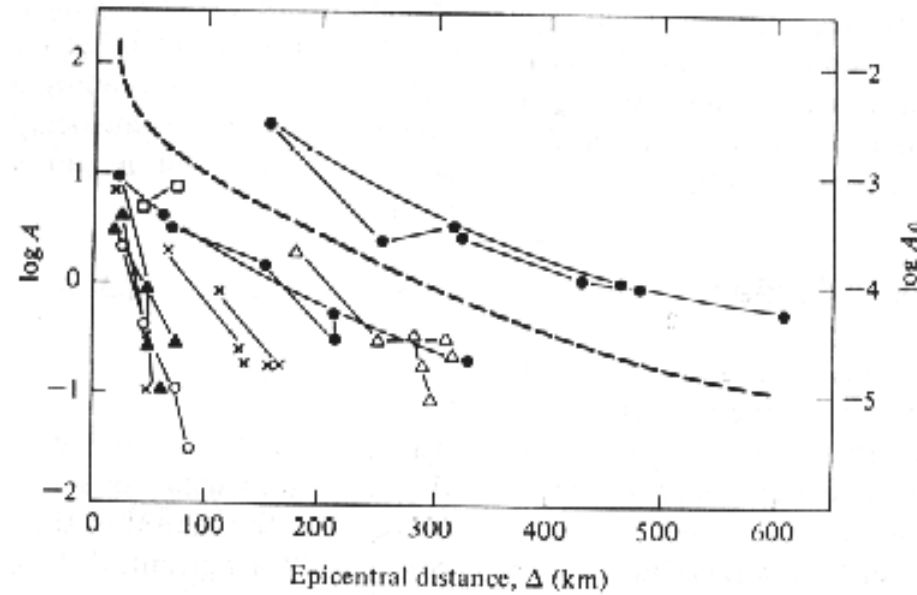

Data from local earthquakes in California

The original Richter scale was based on the observation that the amplitude of seismic waves systematically decreases with epicentral distance.

# Magnitude Scales - Richter

$$M = \log(A/T) + f(\Delta, h) + C_s + C_r$$

$M$  seismic magnitude

$A$  amplitude

$T$  period

$f$  correction for distance

$C_s$  correction for site

$C_r$  correction for receiver

$M_L$  Local magnitude

$M_b$  body-wave magnitude

$M_s$  surface wave magnitude

$M_w$  energy release

# Seismic moment - magnitude

There is a standard way of converting the seismic moment to magnitude  $M_w$ :

$$M_w = \frac{2}{3} [\log_{10} M_0 (\text{dyne-cm}) - 16.0]$$

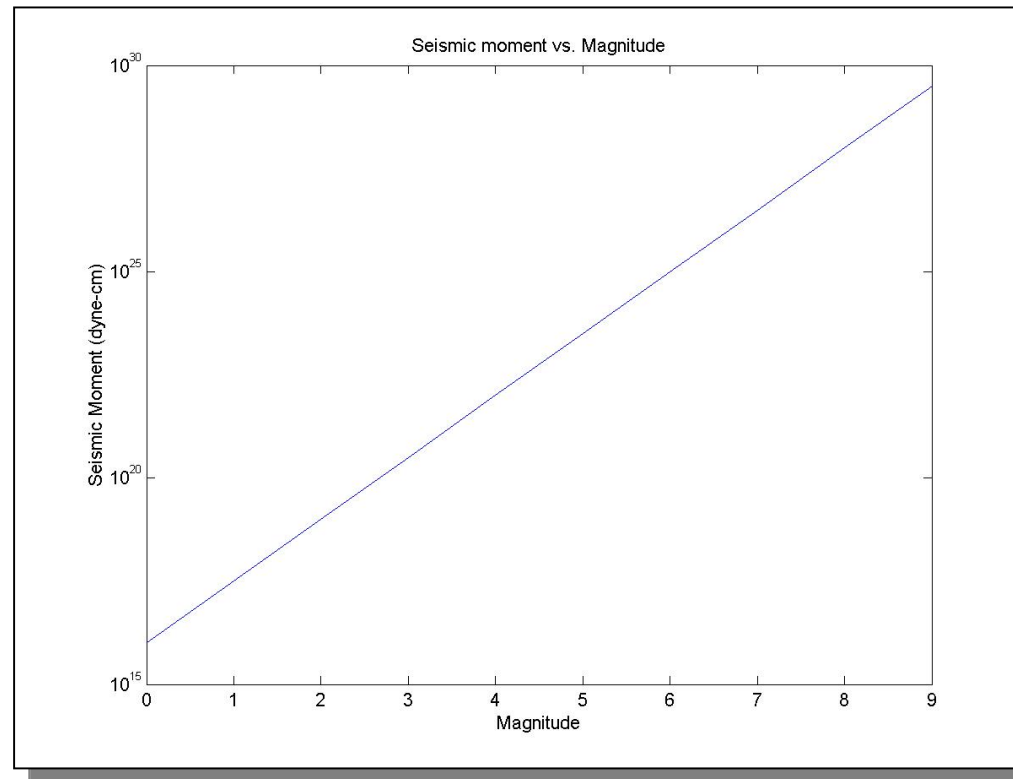

# Seismic energy

Richter developed a relationship between magnitude and energy (in ergs)

$$\log E_s = 11.8 + 1.5M$$

... The more recent connection to the seismic moment (dyne-cm) (Kanamori) is

$$Energy = Moment / 20000$$

# Seismic energy (Examples)

Richter Magnitude	TNT for Seismic Energy Yield	Example (approximate)
-1.5	6 ounces	Breaking a rock on a lab table
1.0	30 pounds	Large Blast at a Construction Site
1.5	320 pounds	
2.0	1 ton	Large Quarry or Mine Blast
2.5	4.6 tons	
3.0	29 tons	
3.5	73 tons	
4.0	1,000 tons	Small Nuclear Weapon
4.5	5,100 tons	Average Tornado (total energy)
5.0	32,000 tons	
5.5	80,000 tons	Little Skull Mtn., NV Quake, 1992
6.0	1 million tons	Double Spring Flat, NV Quake, 1994
6.5	5 million tons	Northridge, CA Quake, 1994
7.0	32 million tons	Hyogo-Ken Nanbu, Japan Quake, 1995; Largest Thermonuclear Weapon
7.5	160 million tons	Landers, CA Quake, 1992
8.0	1 billion tons	San Francisco, CA Quake, 1906
8.5	5 billion tons	Anchorage, AK Quake, 1964
9.0	32 billion tons	Chilean Quake, 1960
10.0	1 trillion tons	(San-Andreas type fault circling Earth)
12.0	160 trillion tons	(Fault Earth in half through center, OR Earth's daily receipt of solar energy)

# Erdbebenstatistik

# Gutenberg-Richter Gesetz

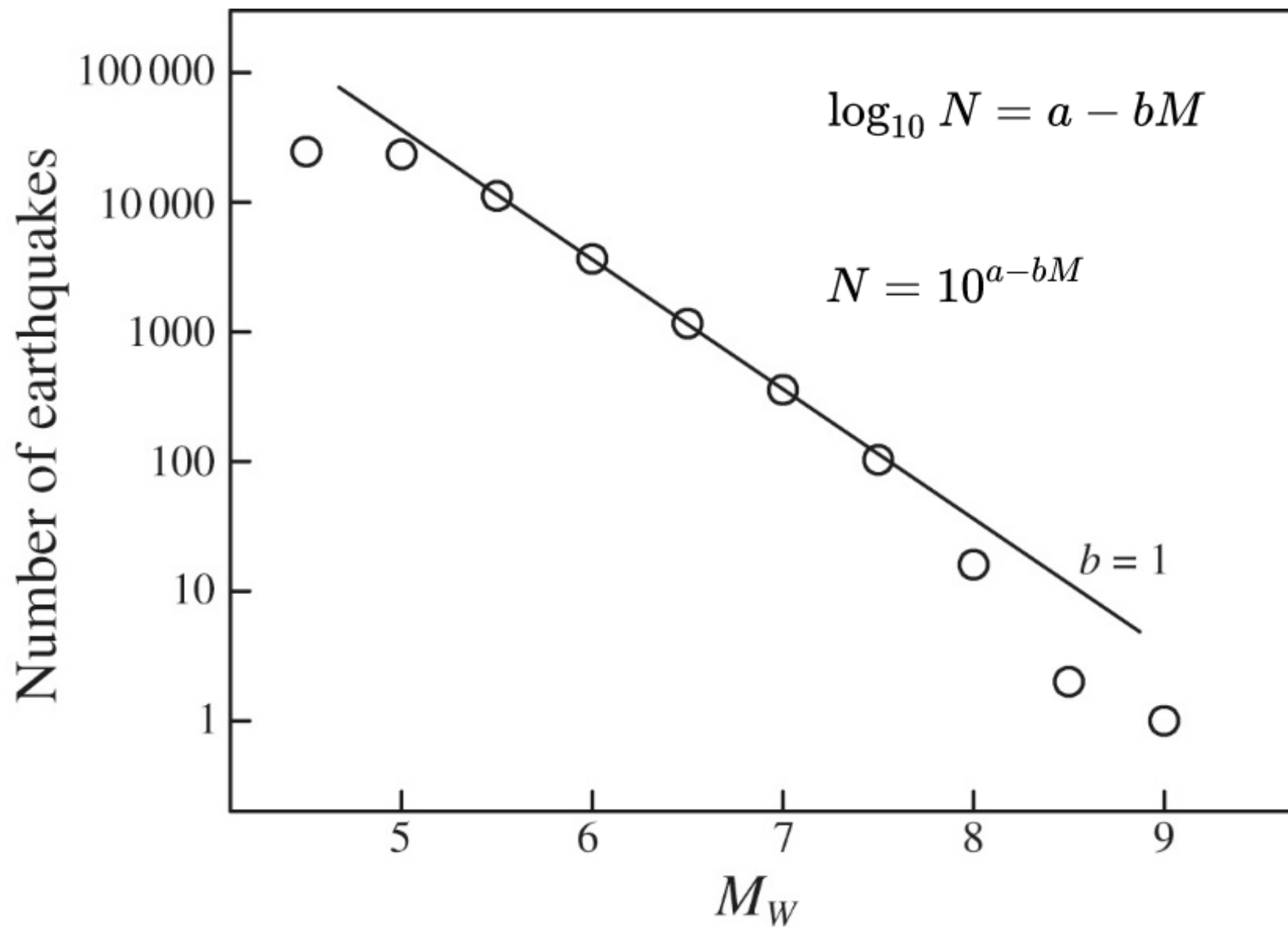

# Seismic sources

Far away from the source (far-field) seismic sources are best described as point-like **double couple** forces. The orientation of the initial displacement of P or S waves allows estimation of the orientation of the slip at depth.

The determination of this **focal mechanism** (in addition to the determination of earthquake location) is one of the routine tasks in observational seismology. The quality of the solutions depends on the density and geometry of the seismic station network.

The size of earthquakes is described by **magnitude** and the **seismic moment**. The seismic moment depends on the rigidity, the fault area and fault slip in a linear way. Fault scarps at the surface allow us to estimate the size of earthquakes in historic times.